



DOGFIGHT
WORKSHOP

Utility $\frac{1}{4}$ Truck

British Special Air Service

scale 1/48

Full 3D printed

1/48 Military Miniature Series No.: 48A09

Overall Length 70 mm



DOGFIGHT
WORKSHOP

Thank you for choosing our product.
Our models are made in
3D printing technology from
photopolymer resins.

Below are some steps, tips and tricks on how
to prepare our product for building.

Happy Modelling !



A few tips and tricks how to prepare our models

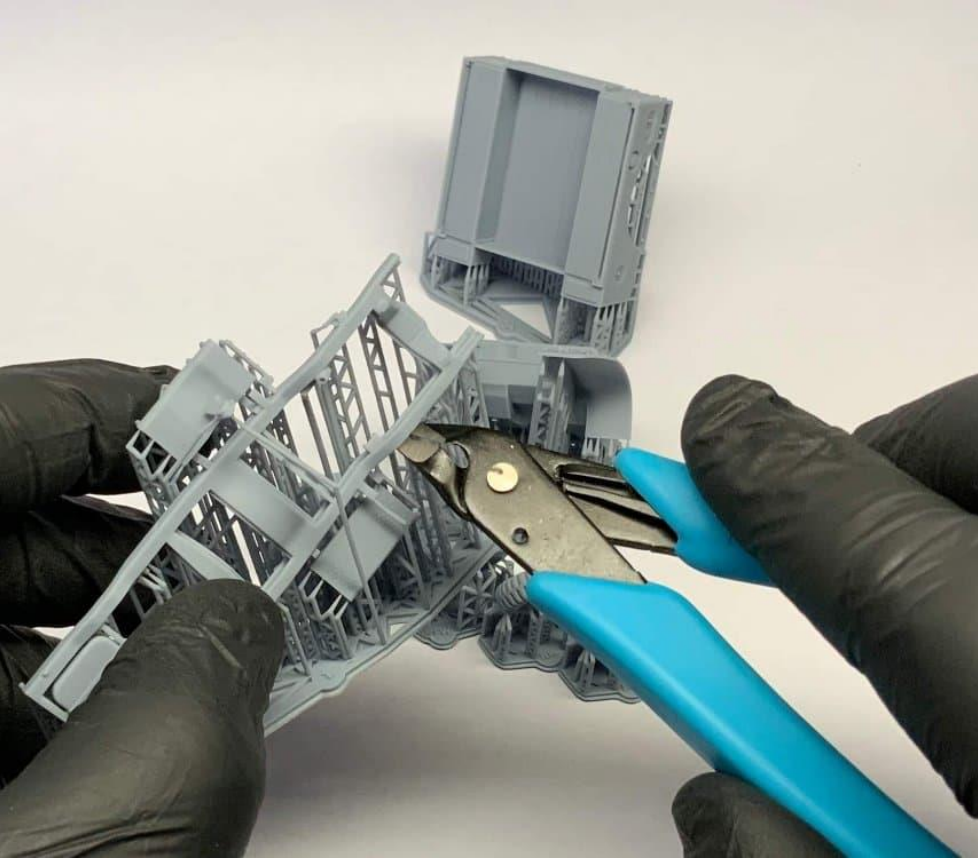

1 - Cutting off printing supports ...

- modelling knife*
- modelling cutter*
- modelling saw*



- 2 - Grinding and sanding ...*
- modelling grinding wool*
 - modelling sponge*
 - modelling file*

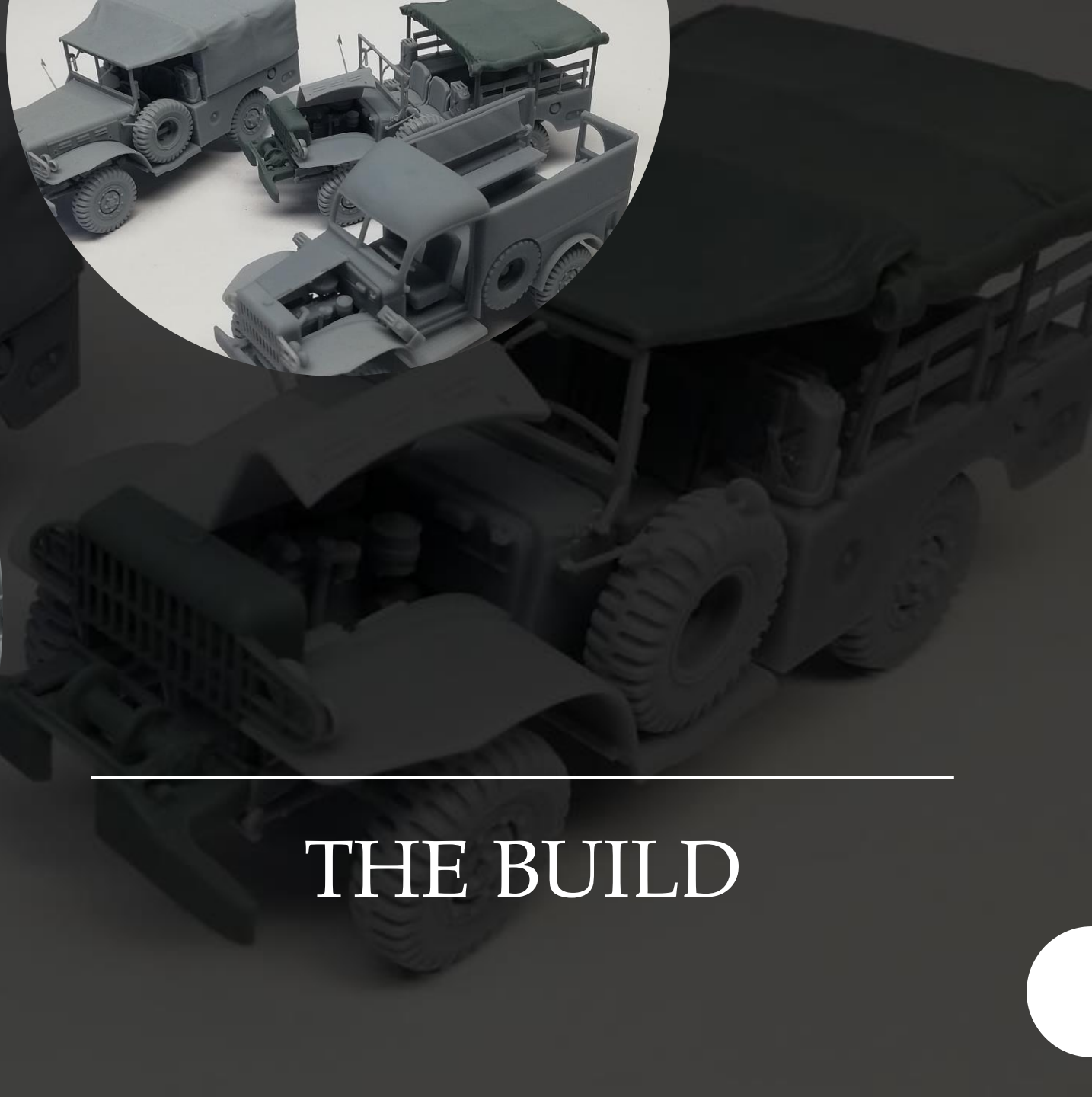
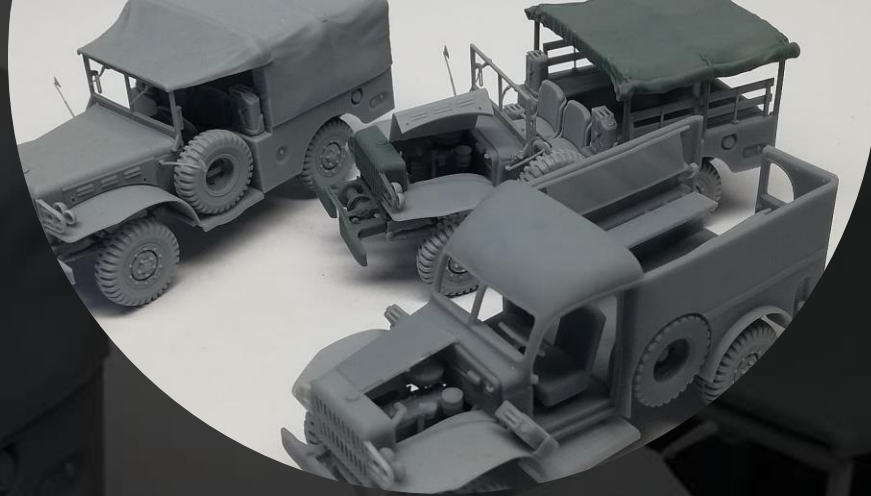
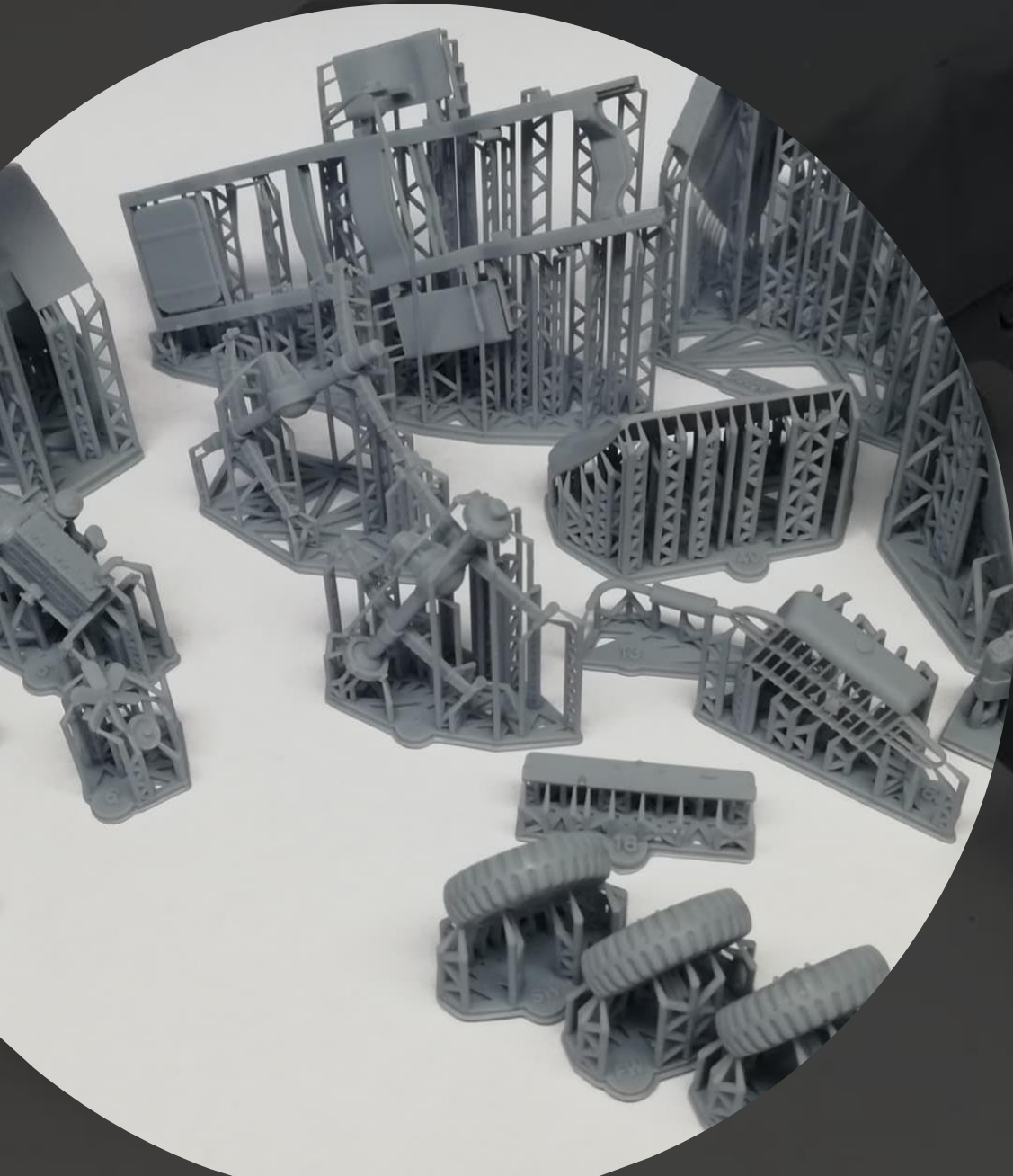

THE BUILD

Utility 1/4 Ton truck
&
British SAS Jeep

Body components

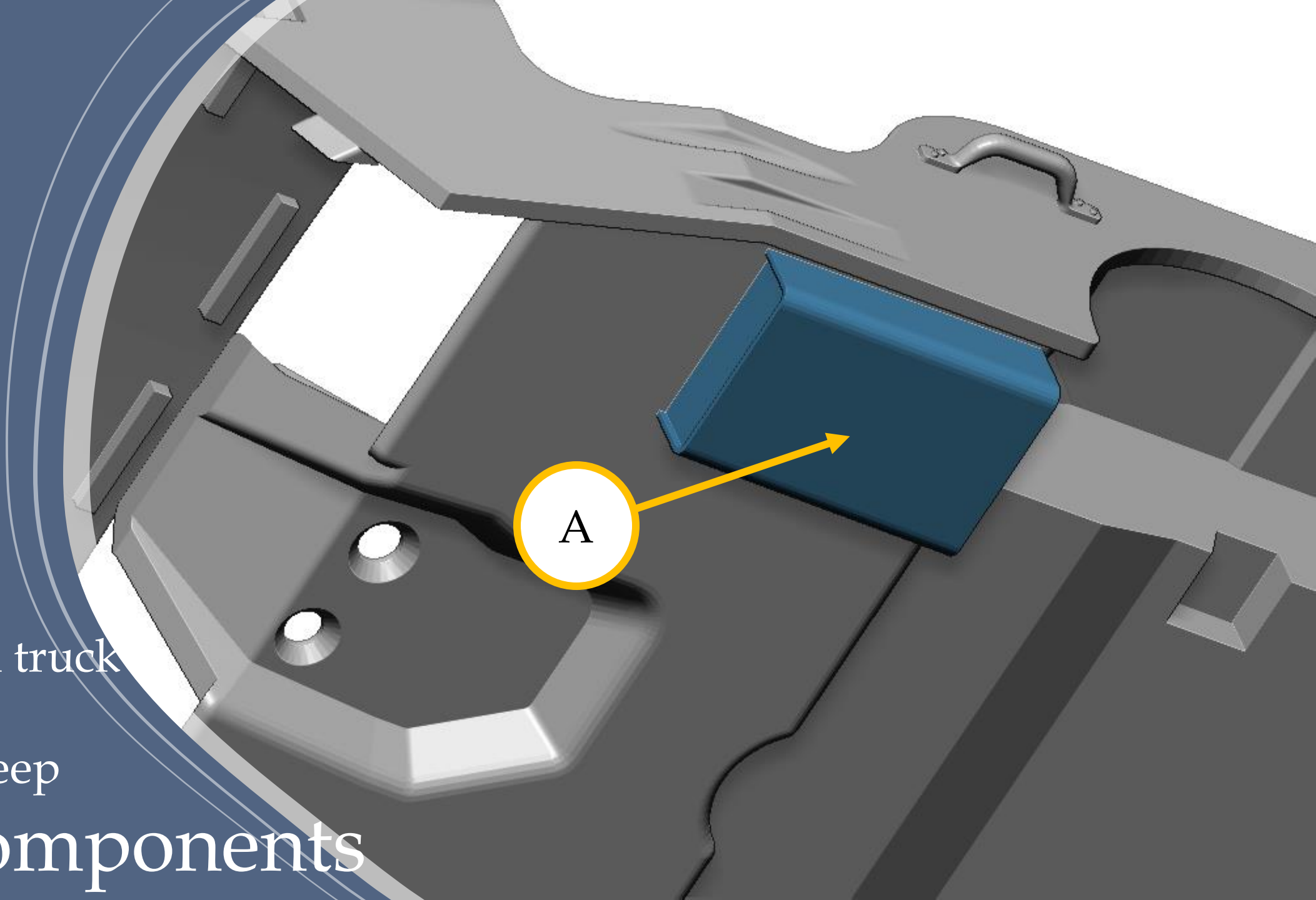

Utility ¼ Ton truck
&
British SAS Jeep

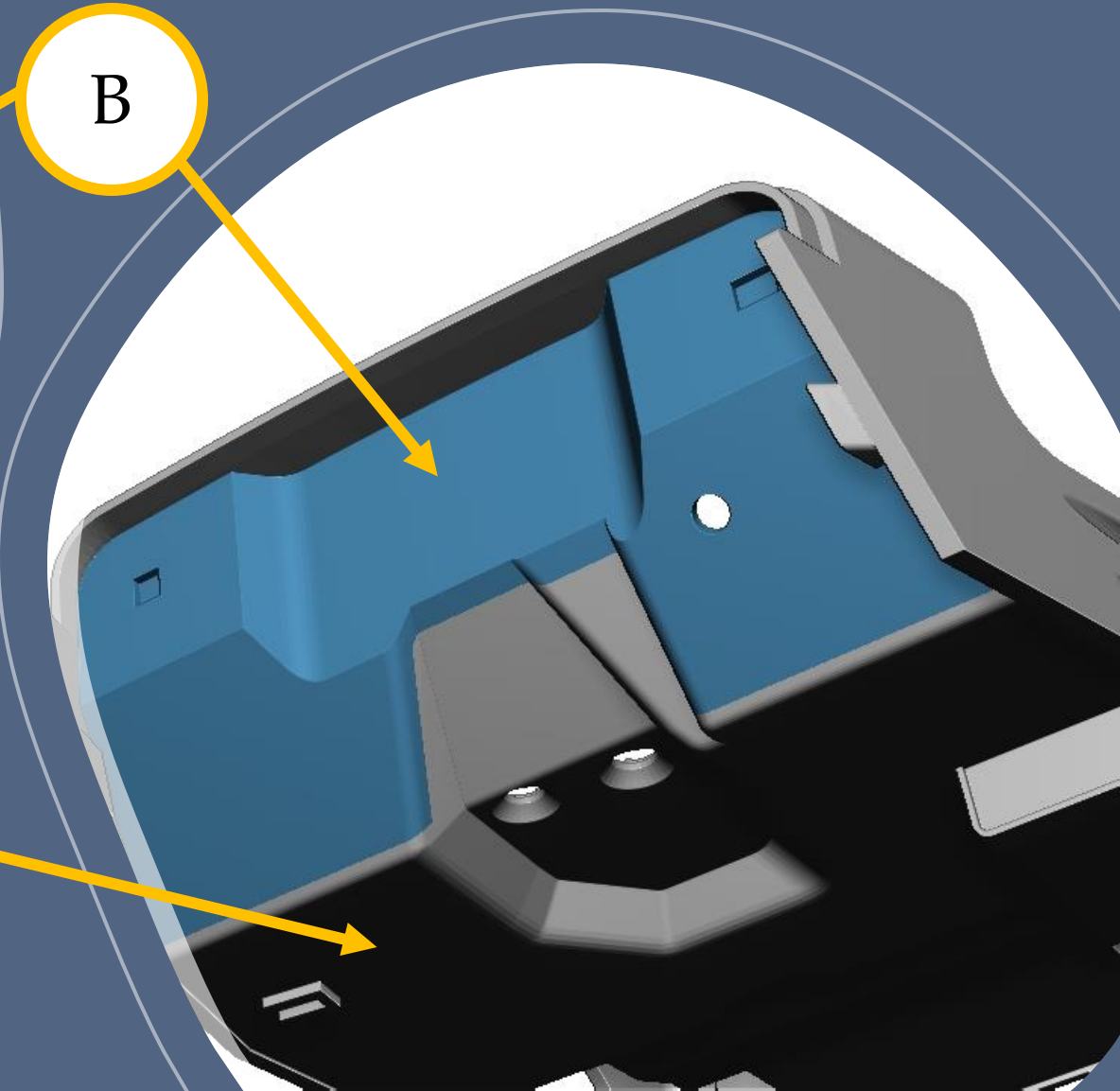
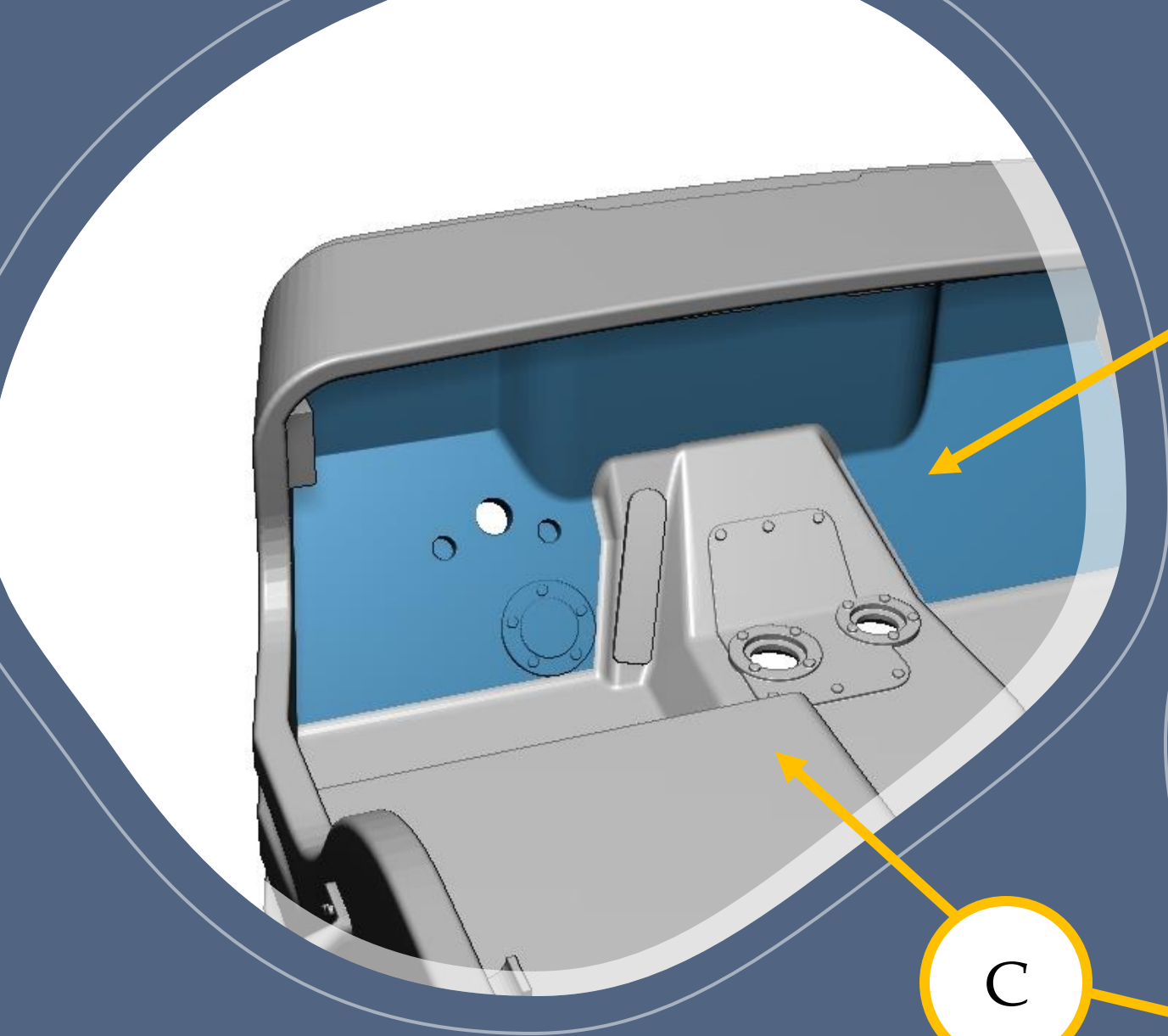

Utility 1/4 Ton truck
&
British SAS Jeep
Connection points

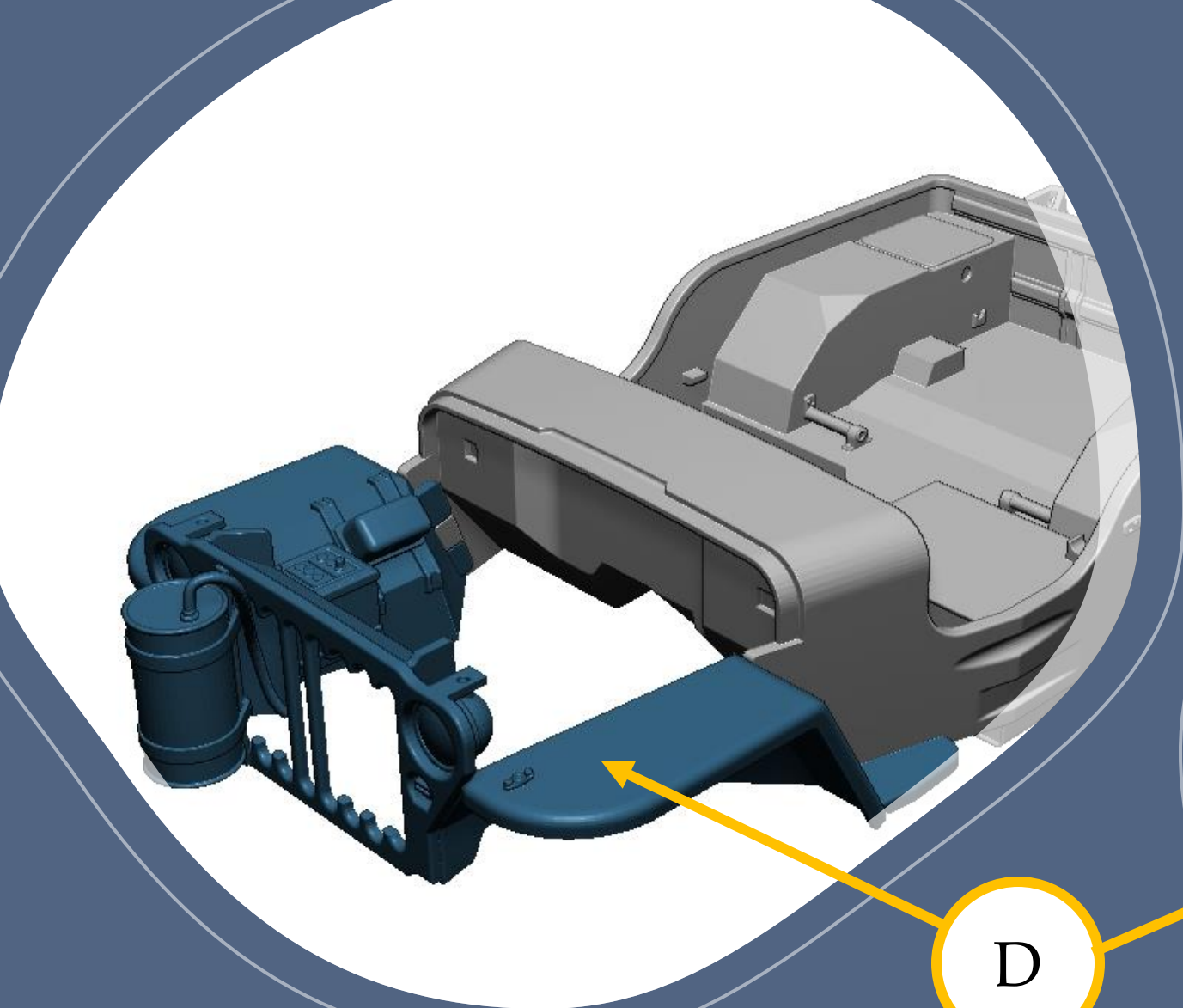

D

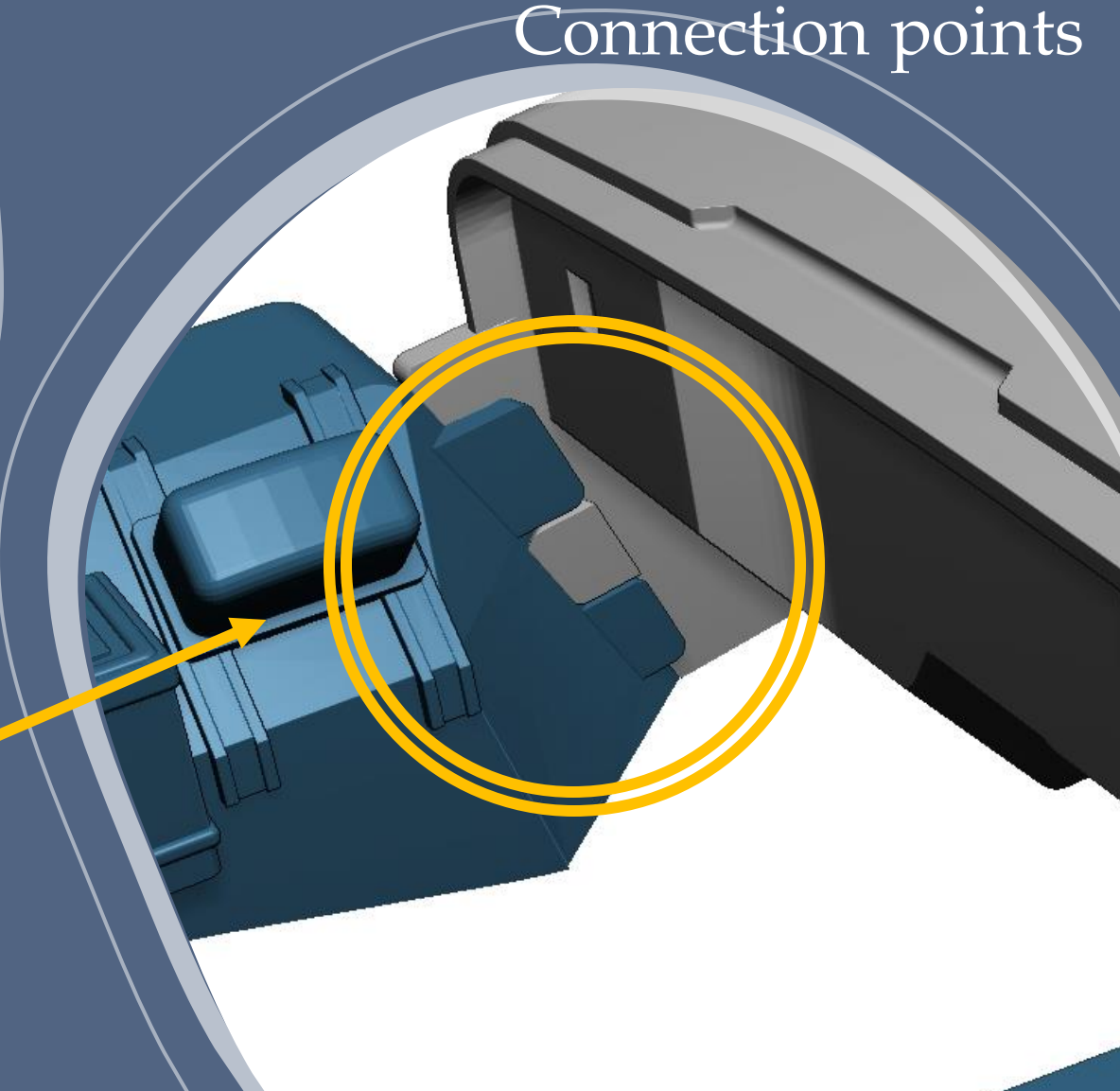

Utility 1/4 Ton truck
&
British SAS Jeep
Body complete

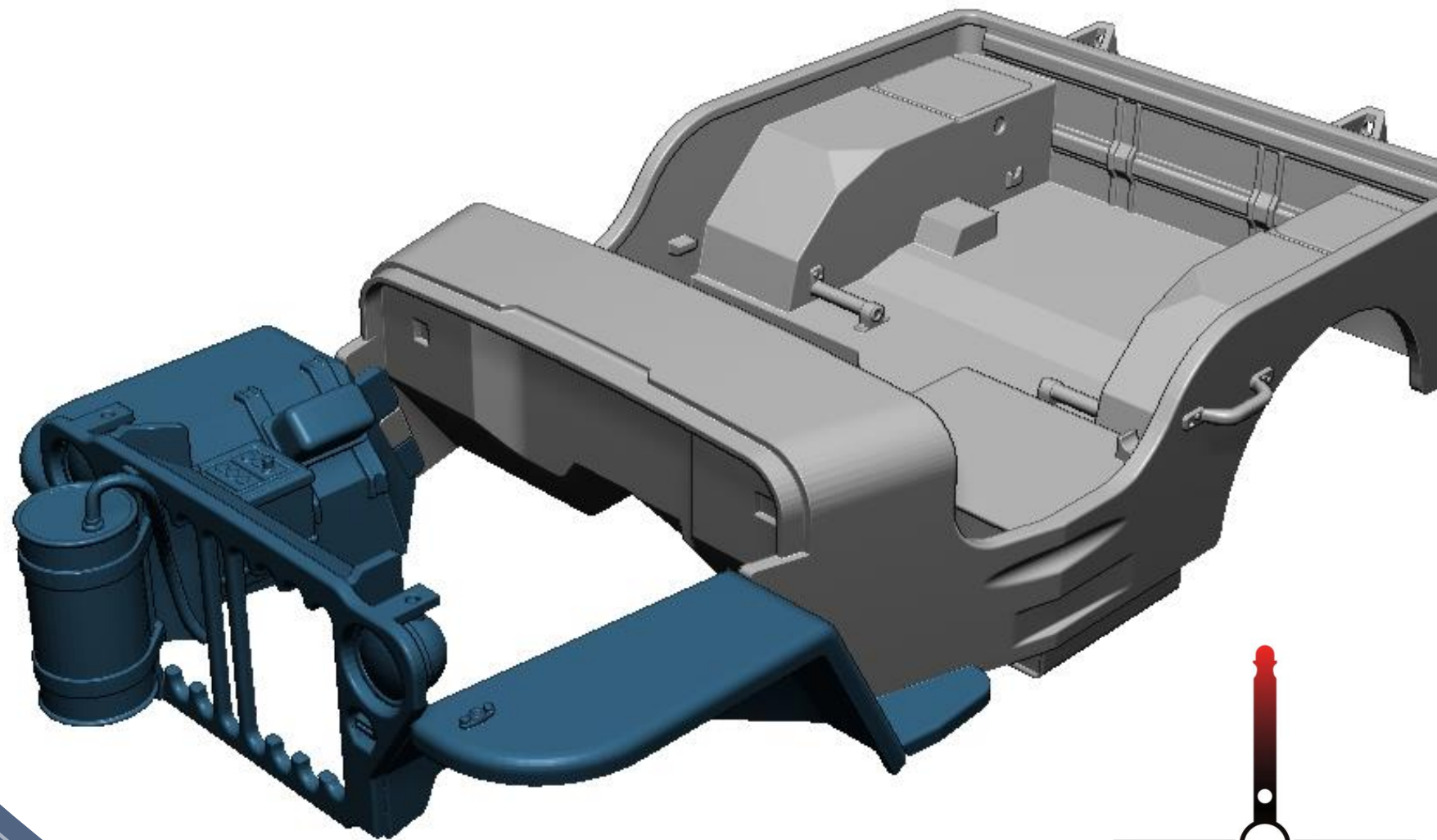

48A14
British SAS Jeep

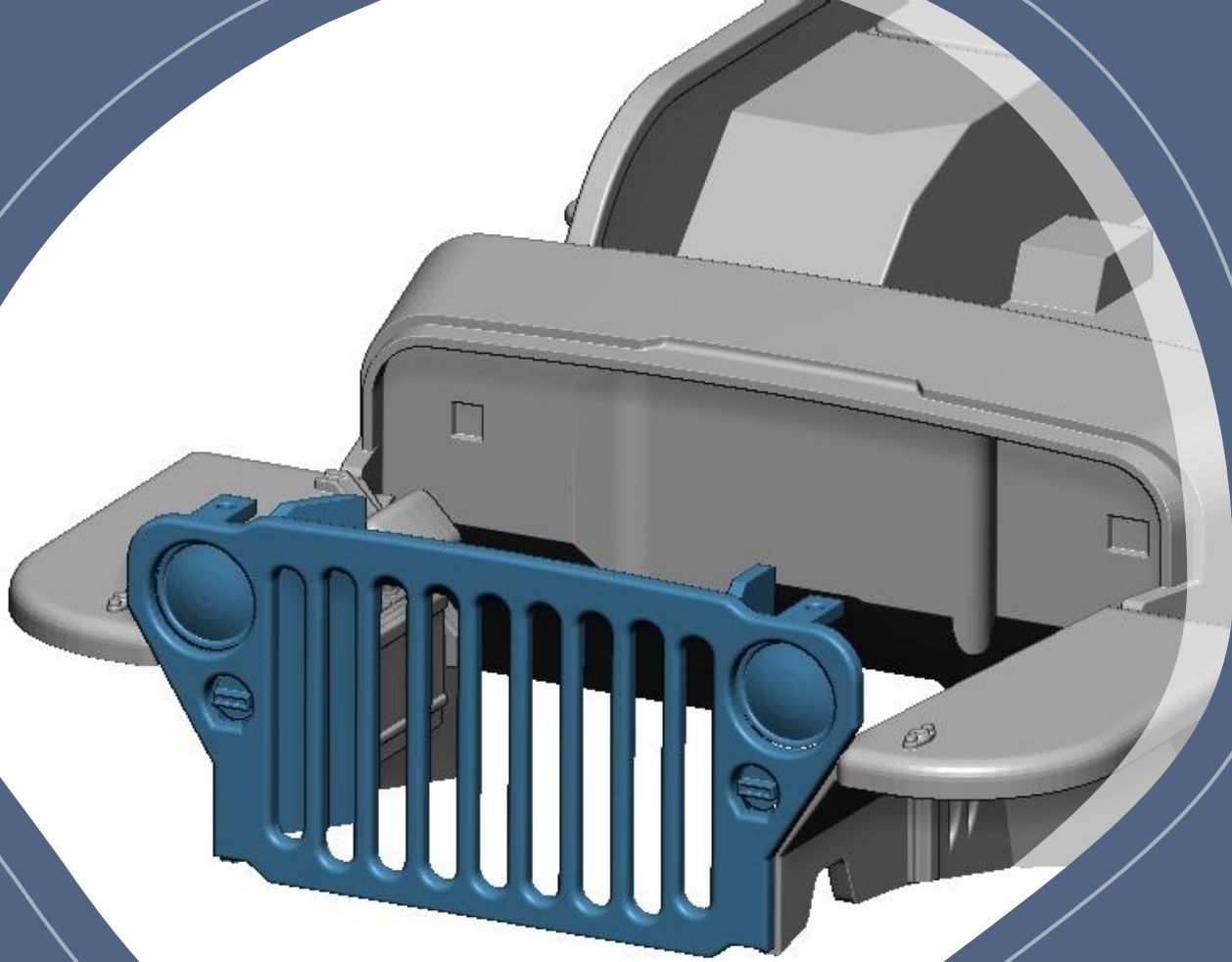

48A12
Utility 1/4 Ton truck

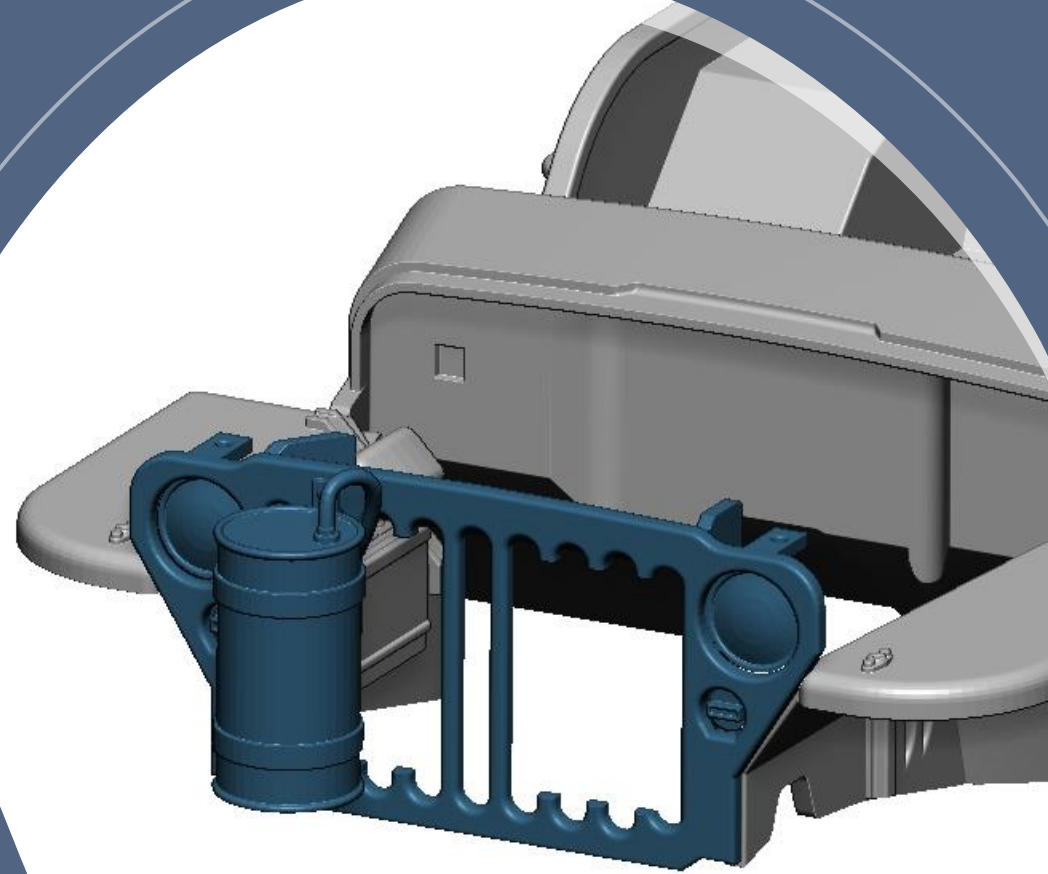

48A12 & 48A14 Frame & Engine

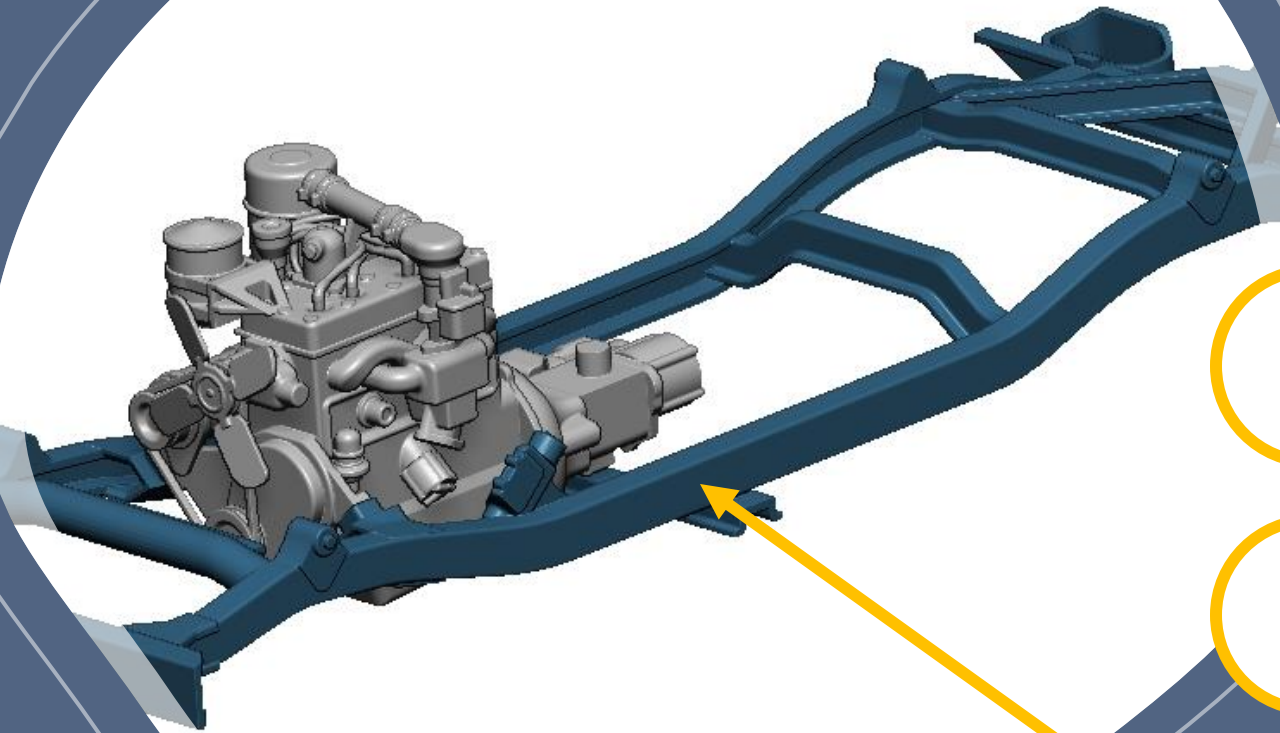

2

3

4

1

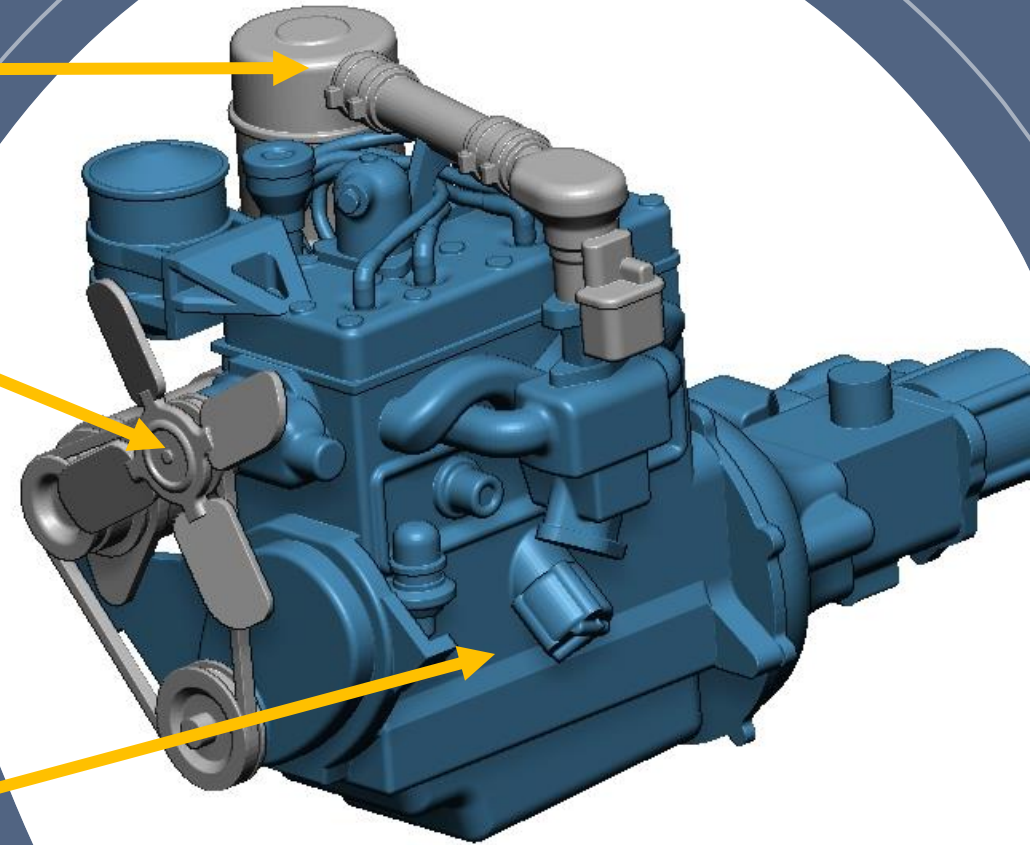

48A12 & 48A14 Radiator

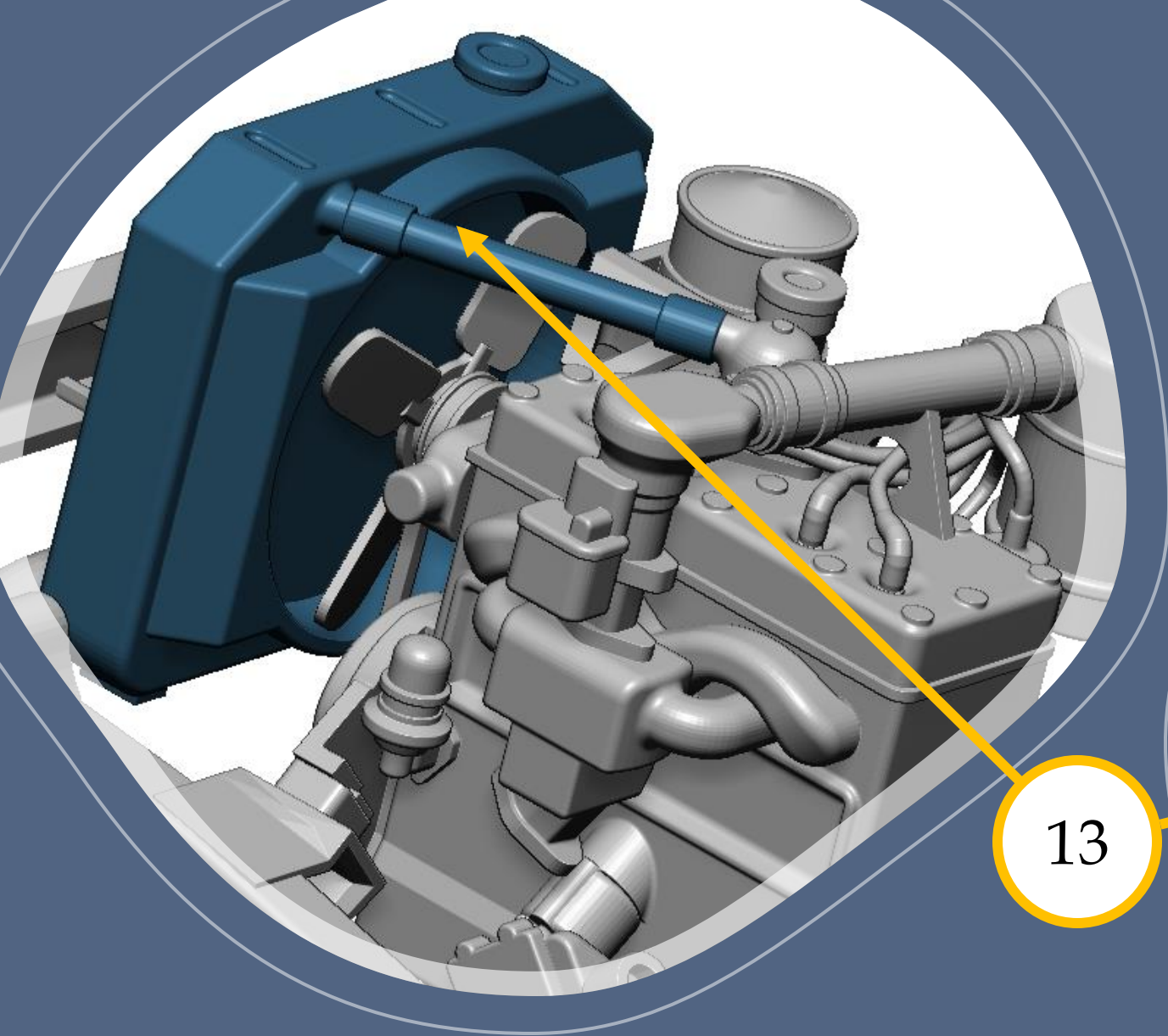

13

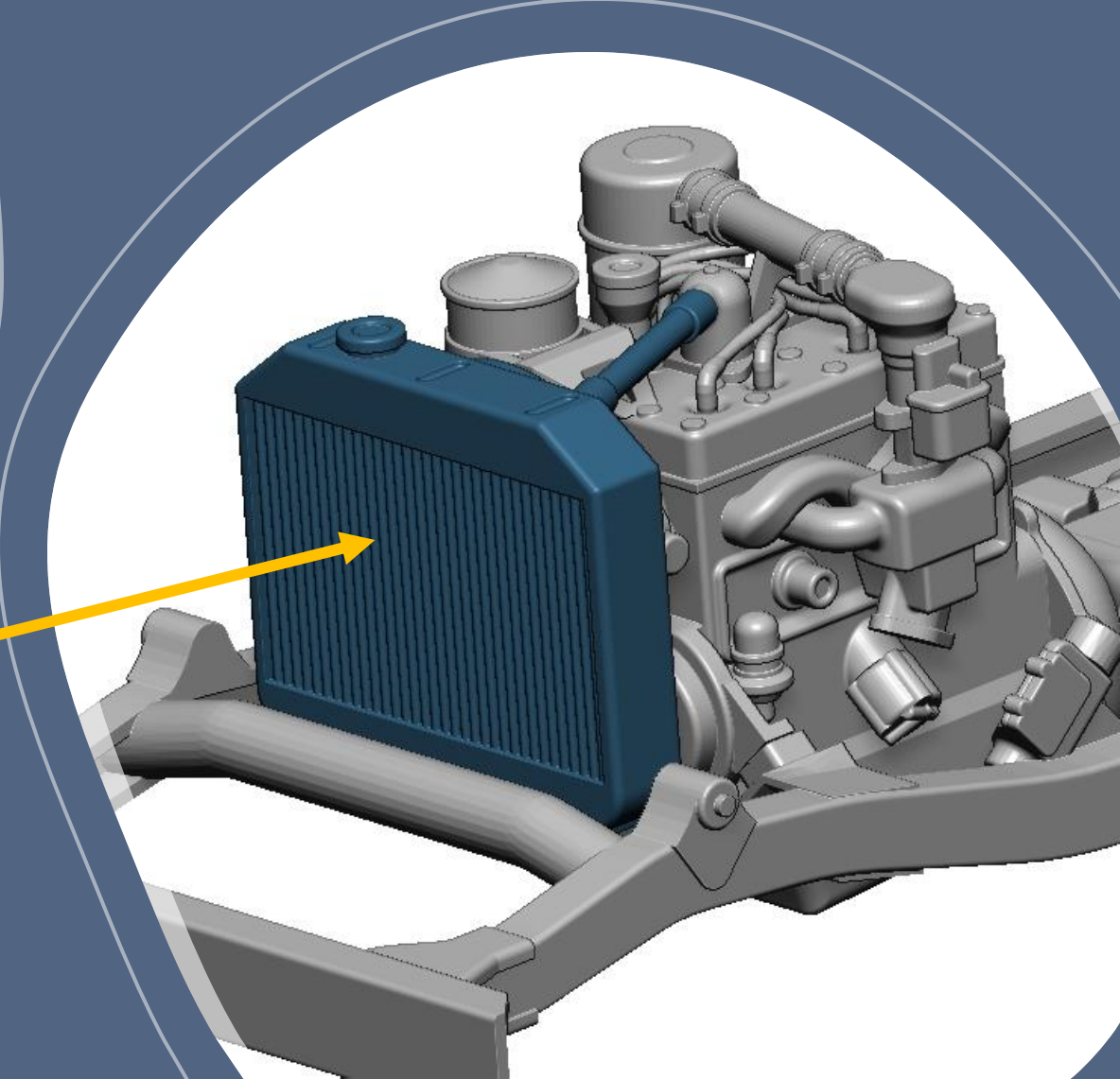

48A12 & 48A14
Suspension &
mission

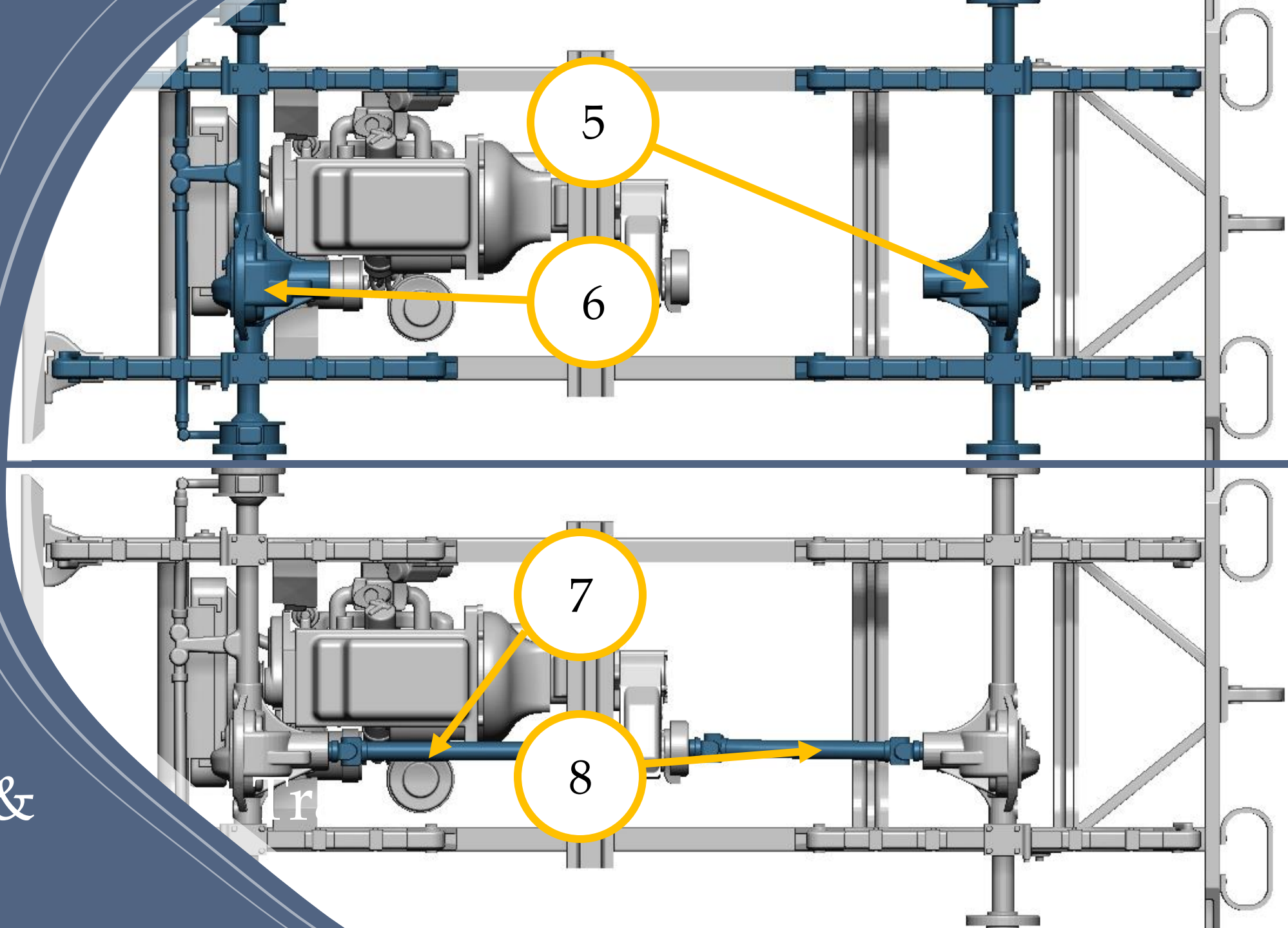

48A12 & 48A14 Shock absorbers

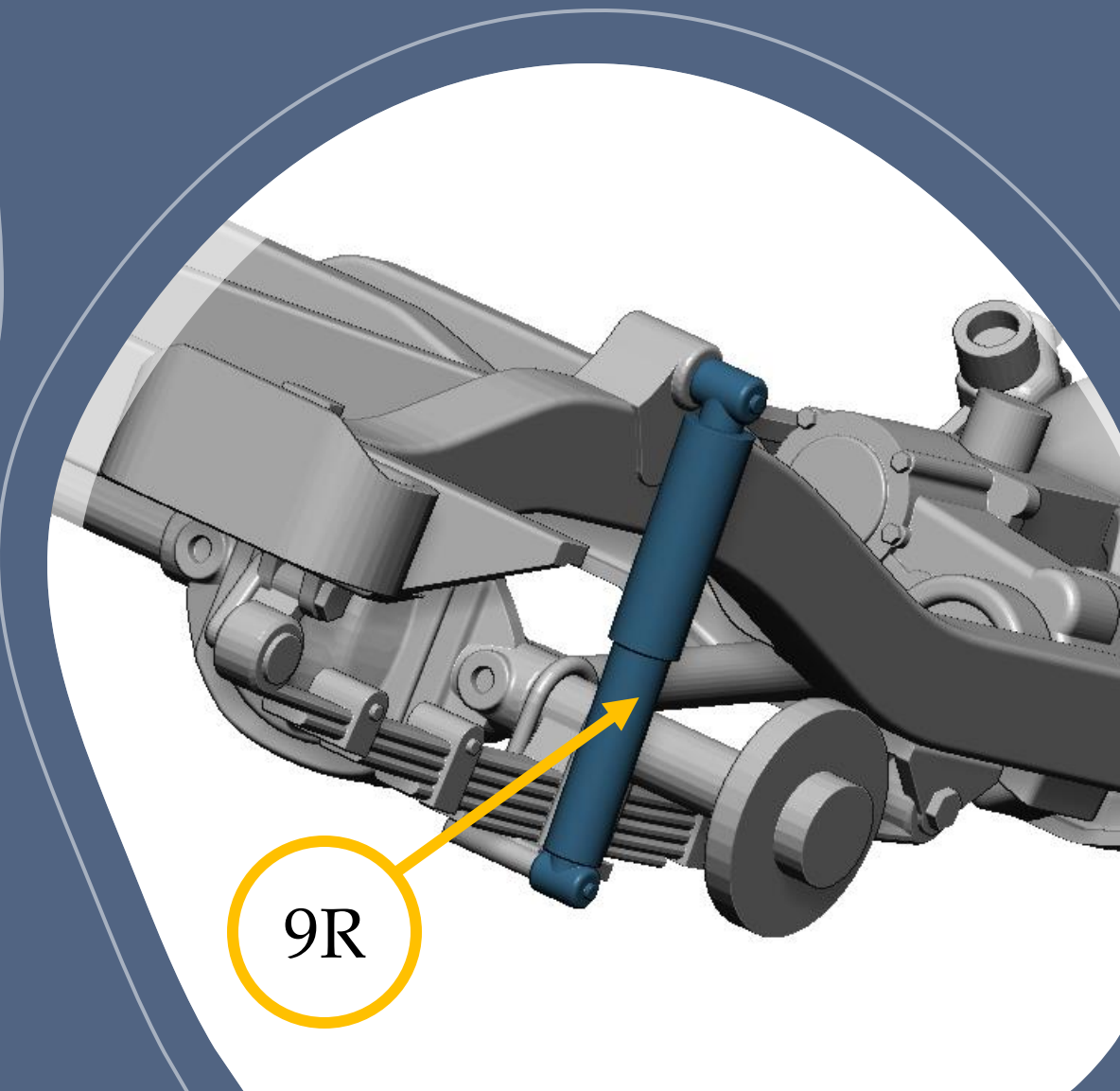
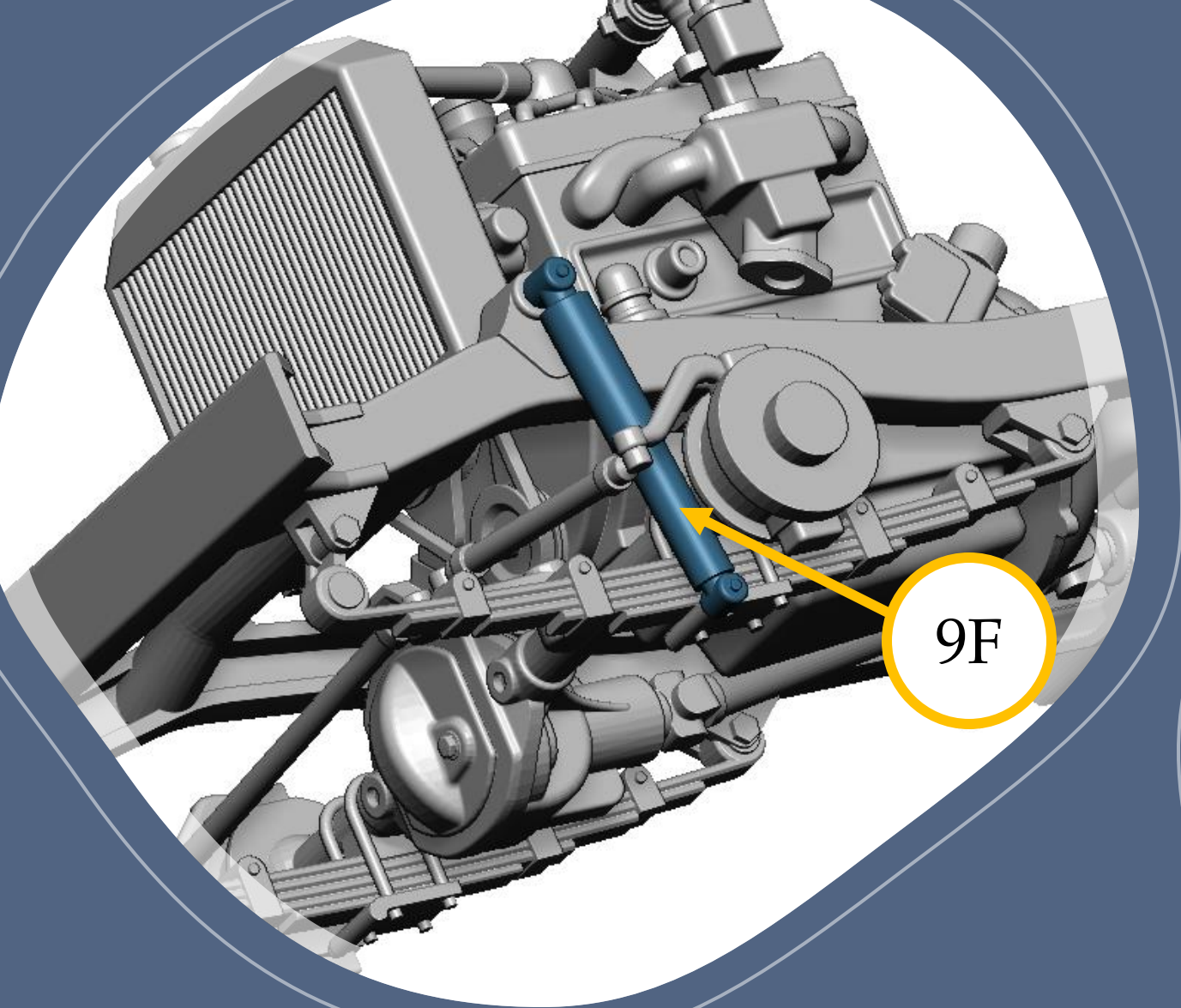

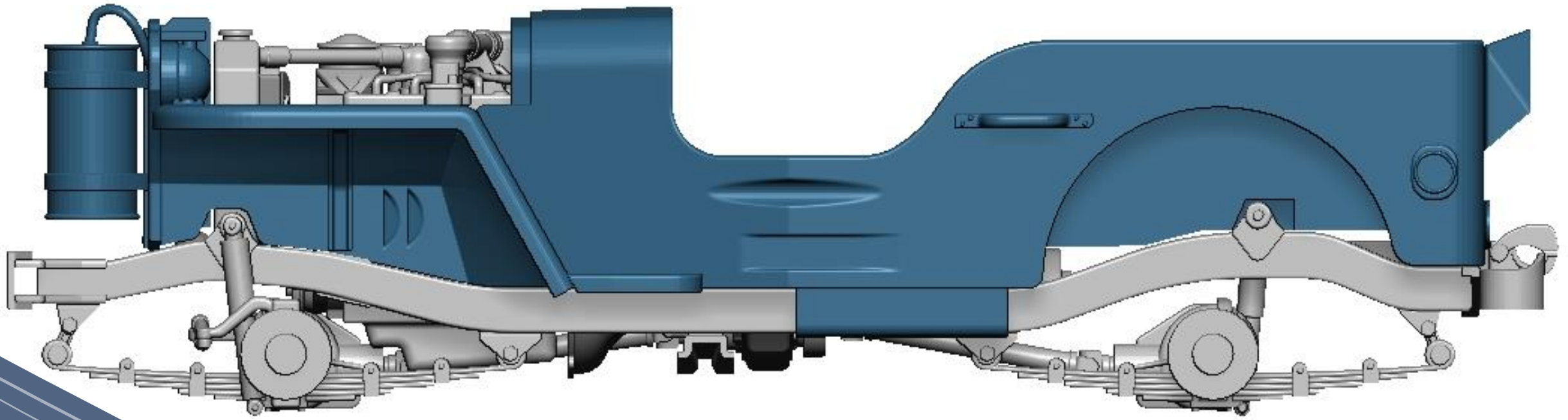

48A14
Body

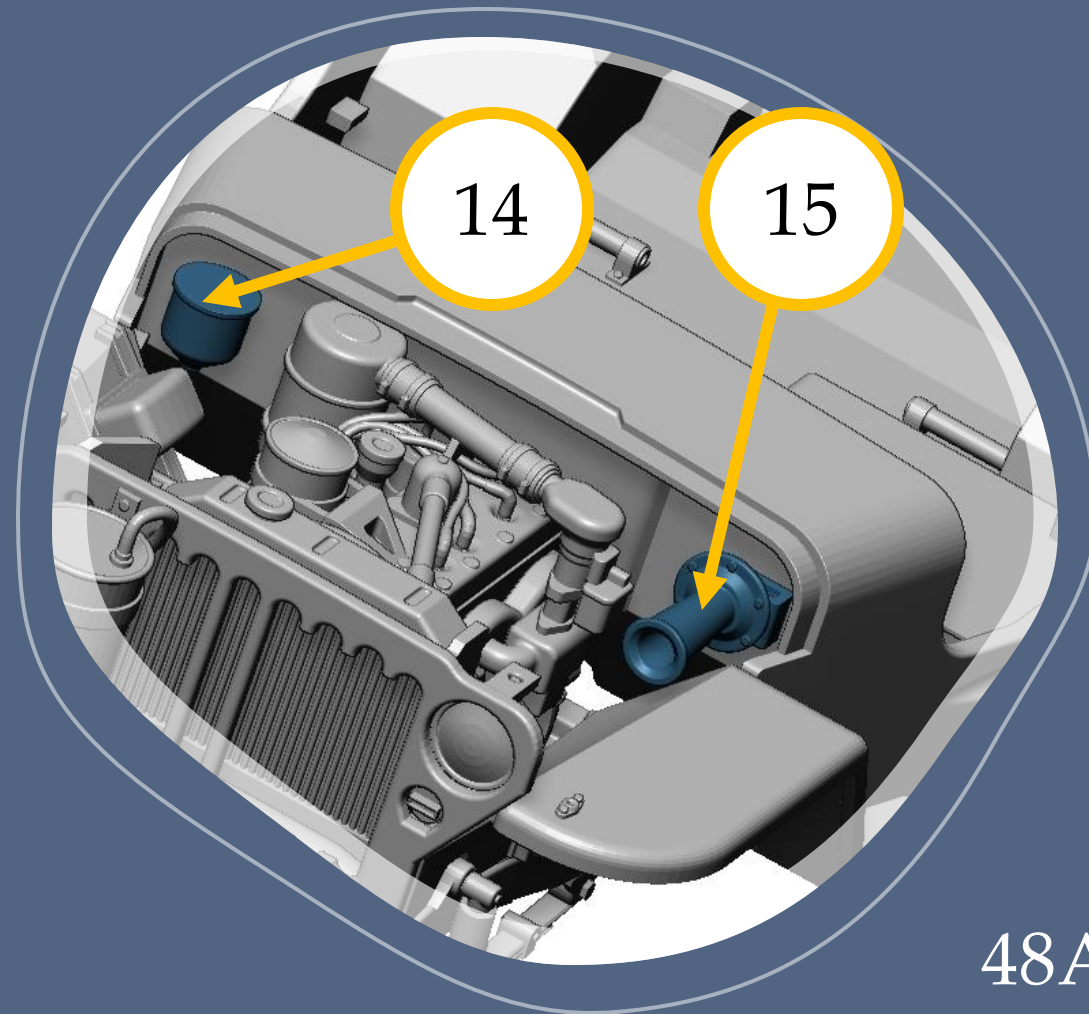
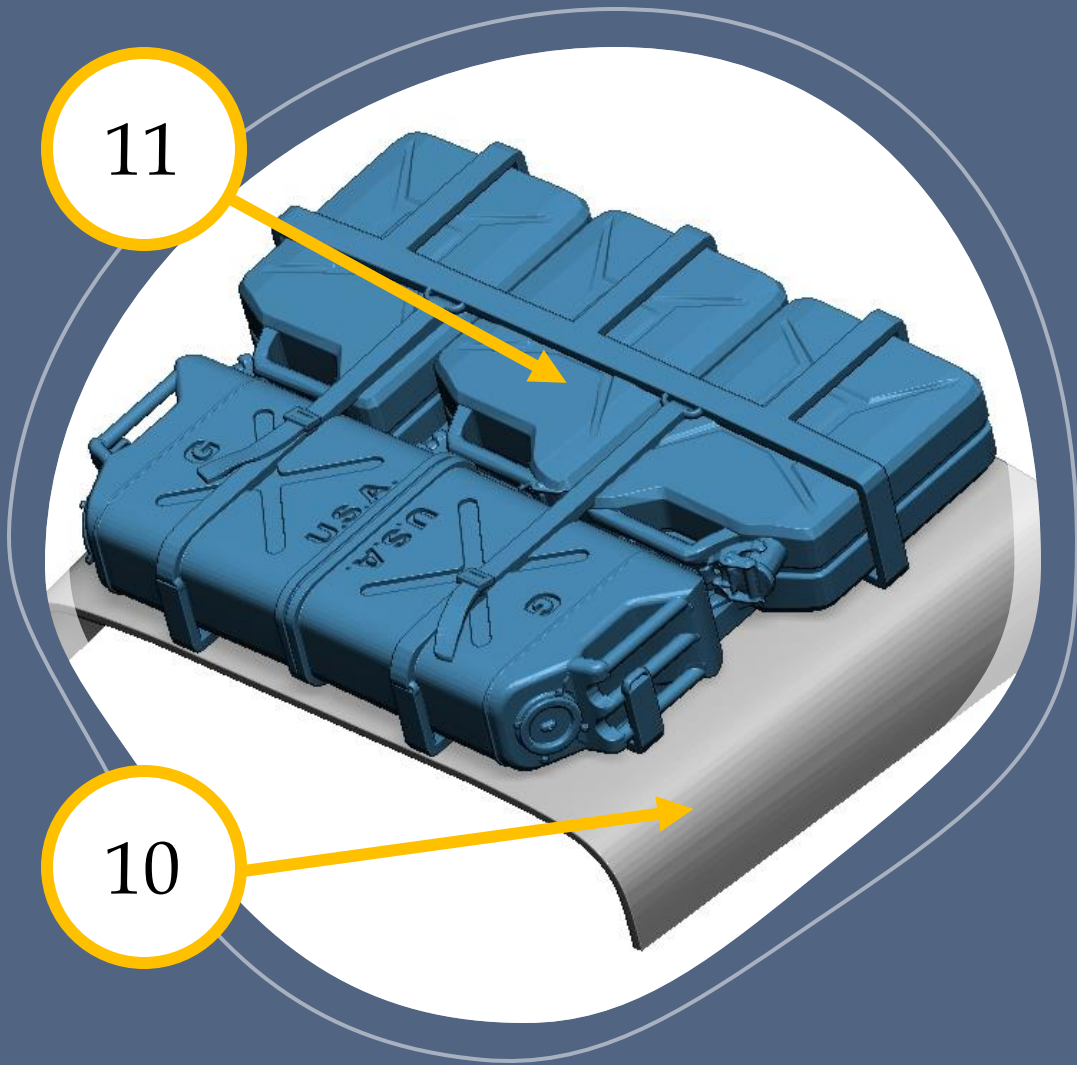

48A14
Engine Hood & Canisters,
Engine Components

48A14
Canisters

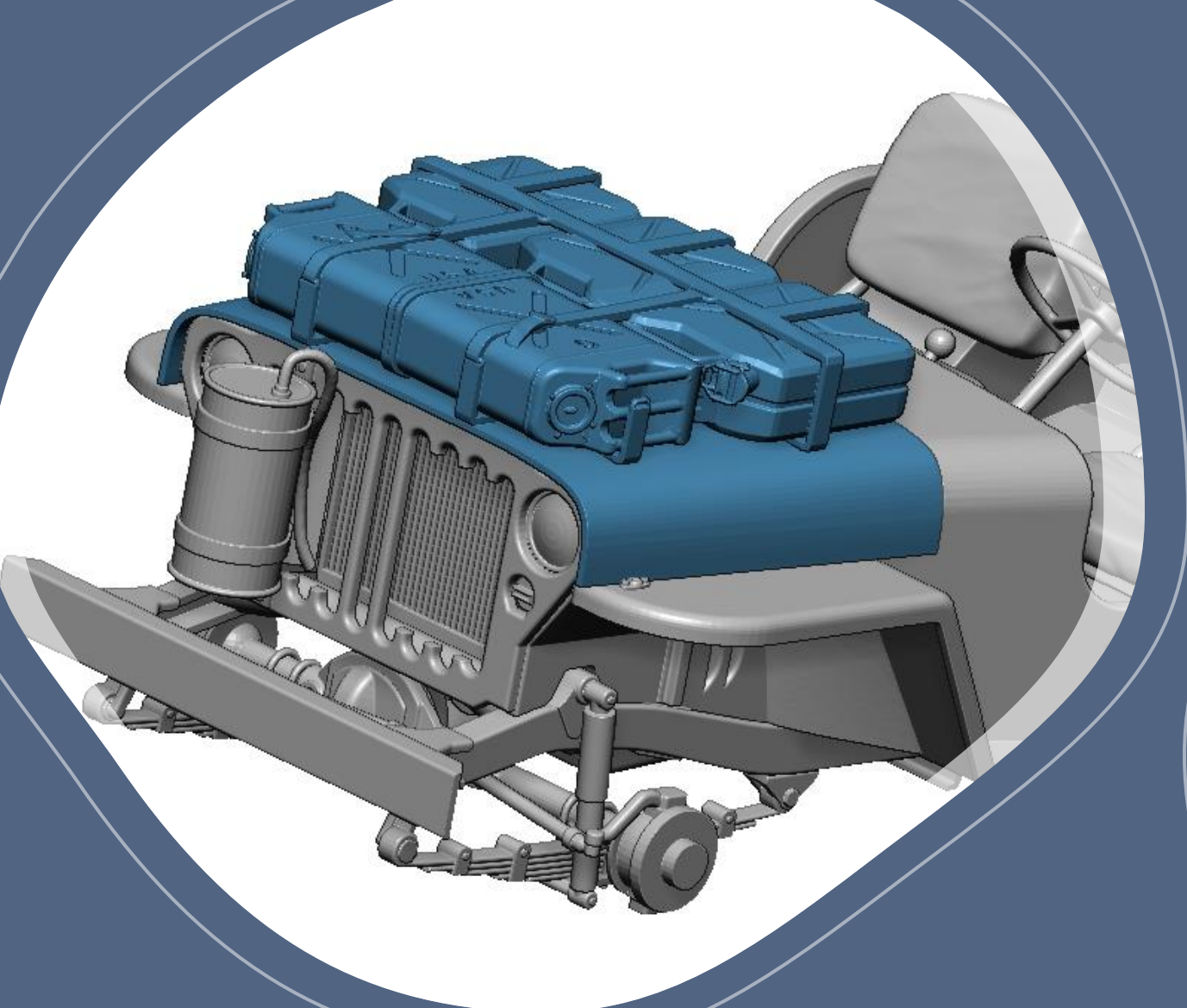

48A14
Interior parts

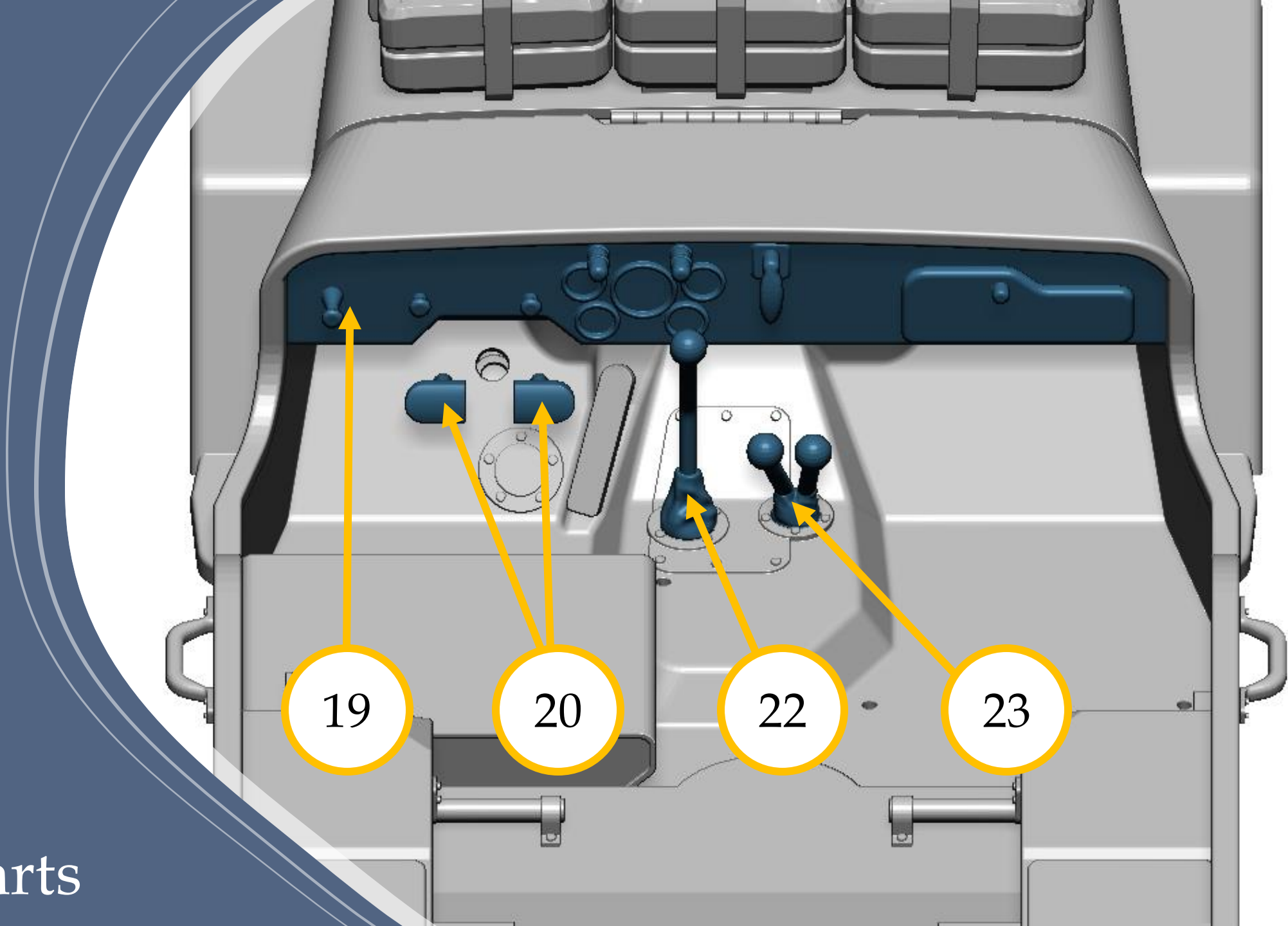

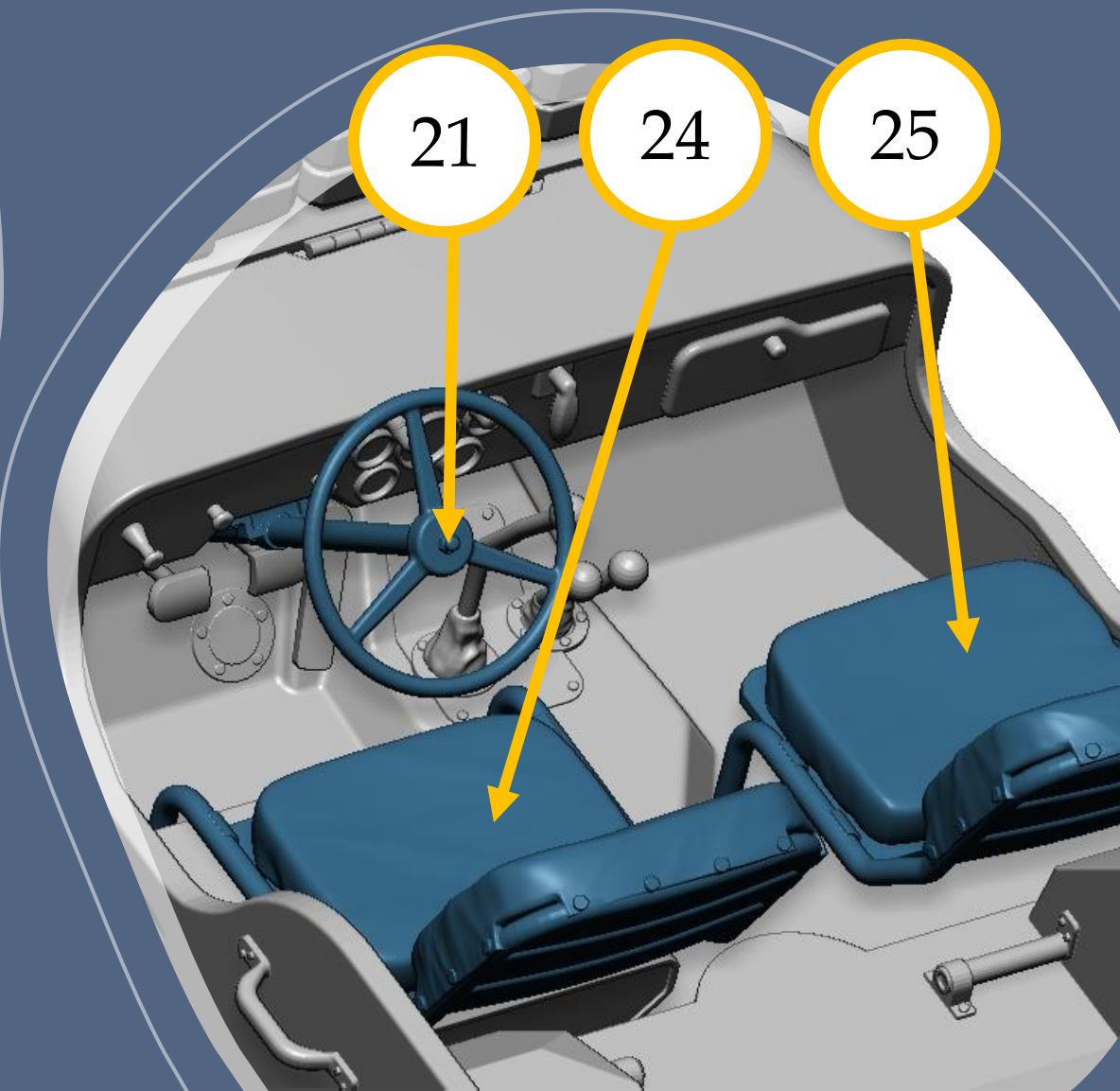

48A14
Interior parts

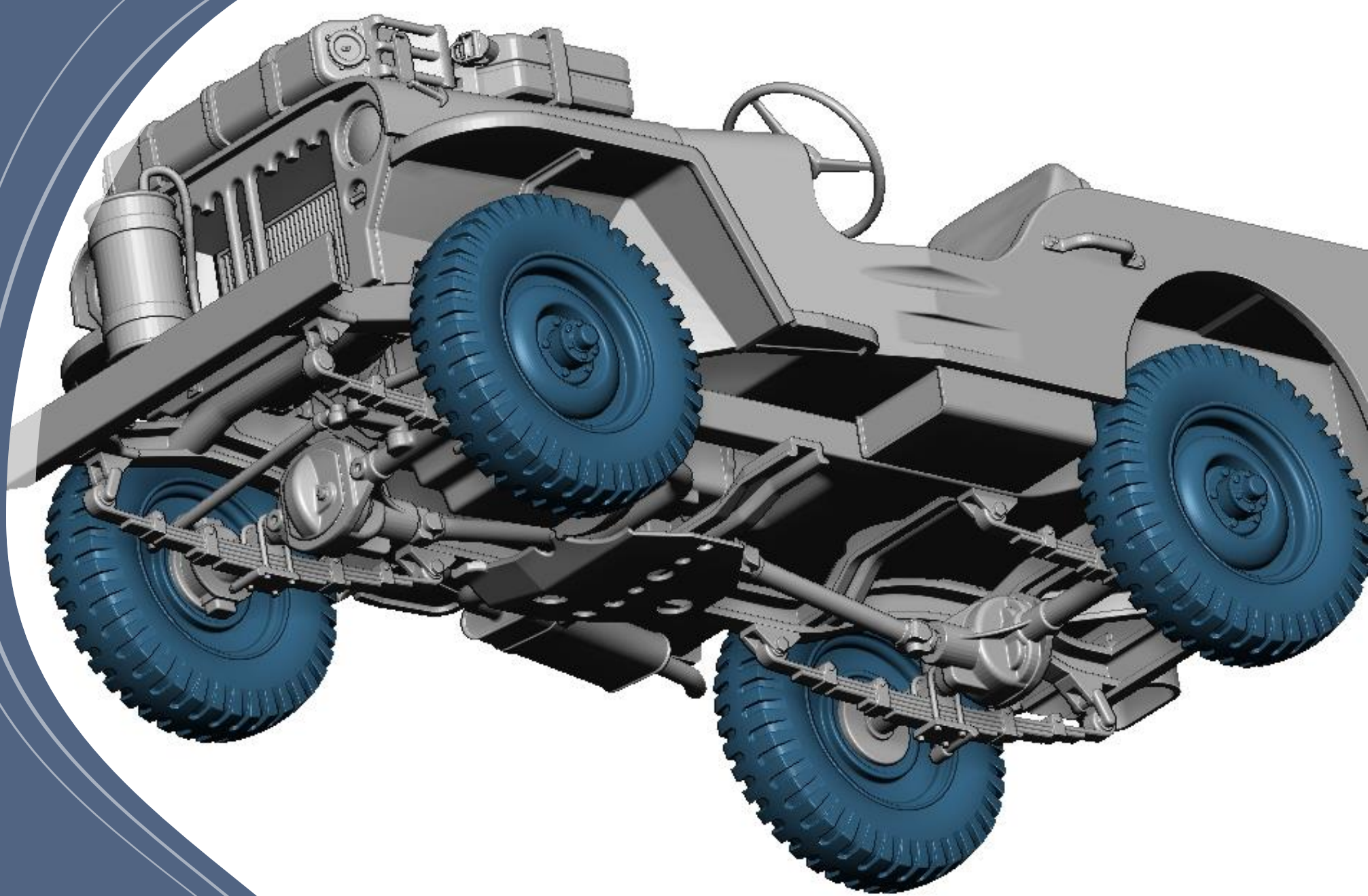

48A14
Wheels -
Two types tire option

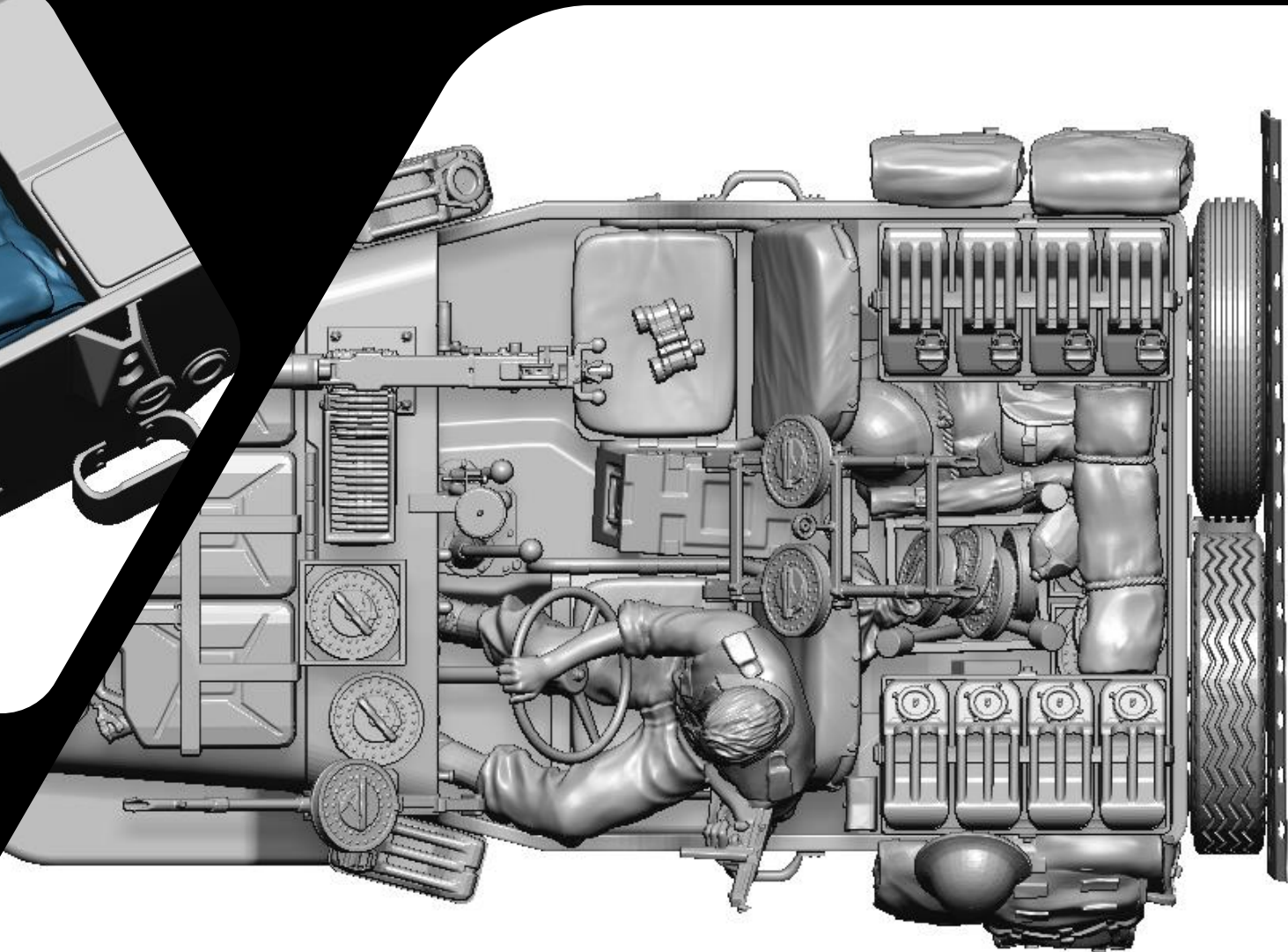
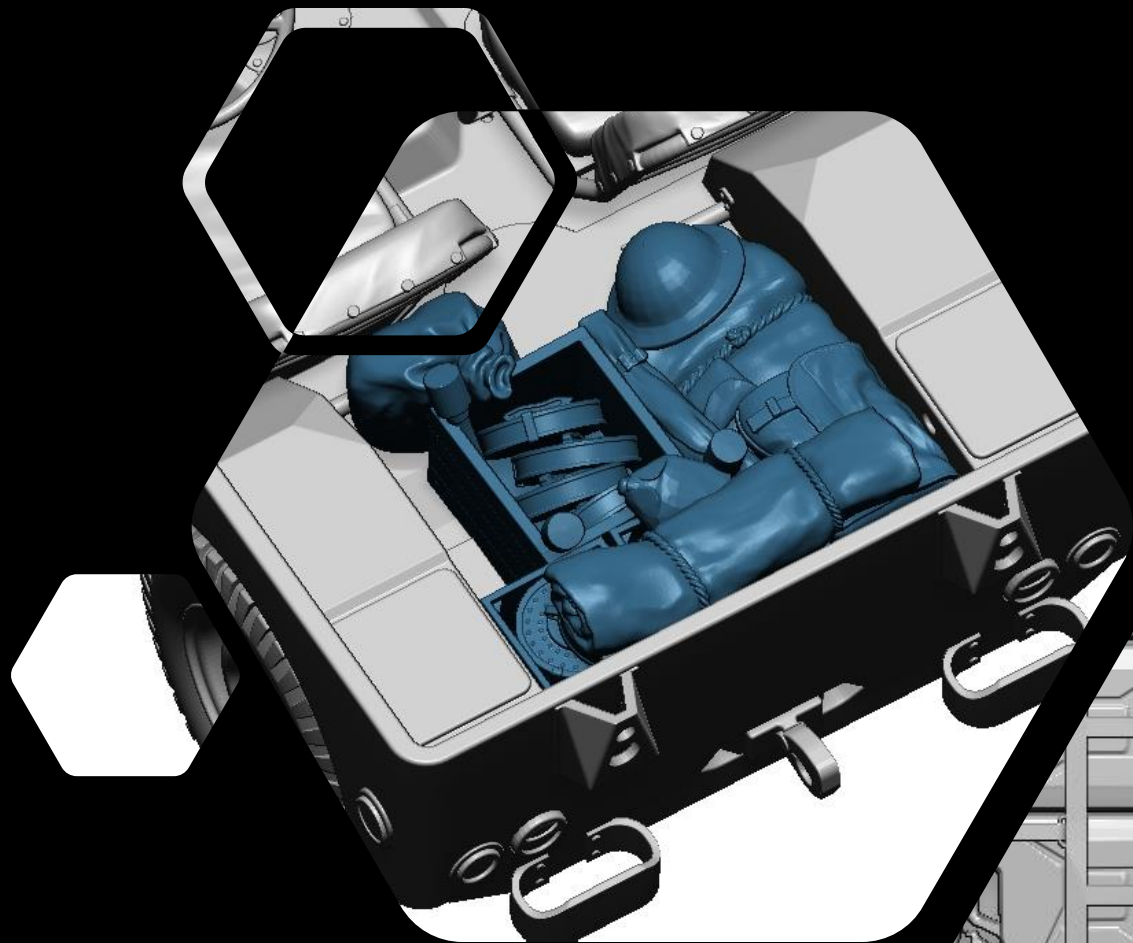

48A14
Interior Equipment
Optional use

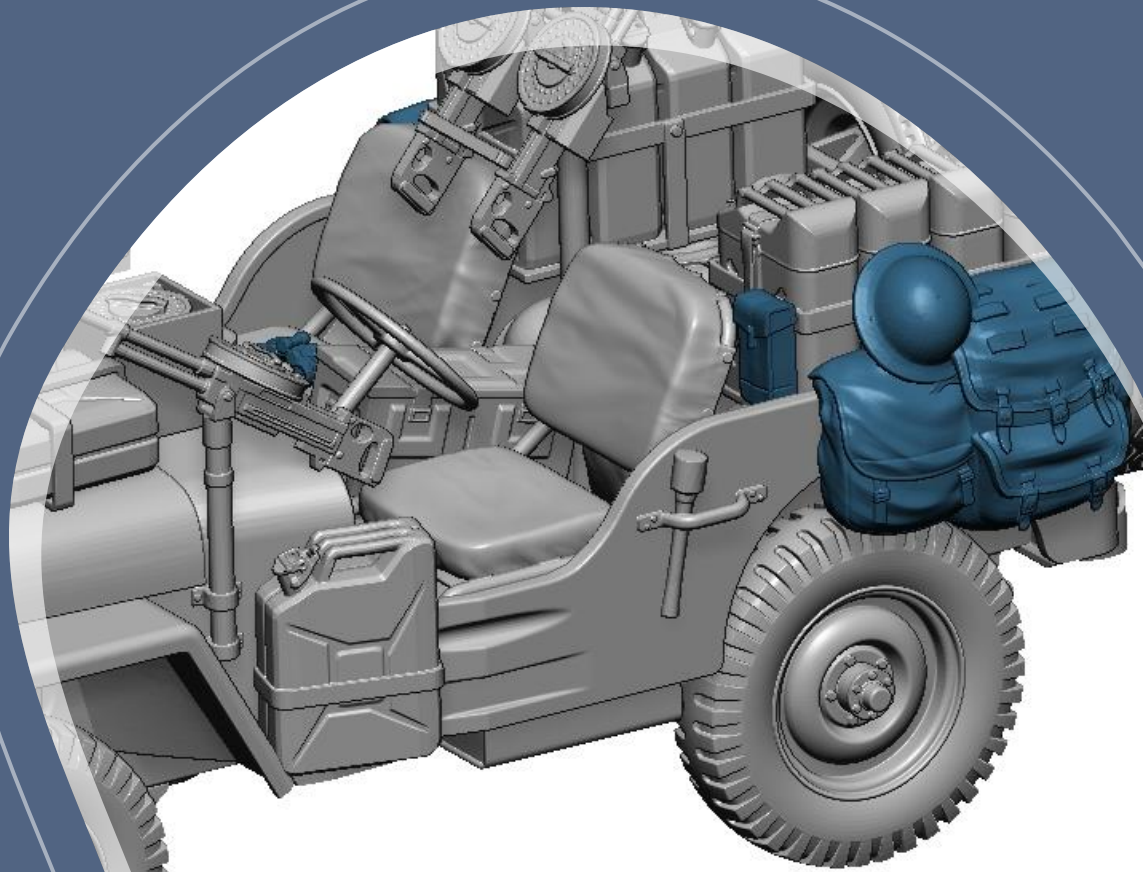
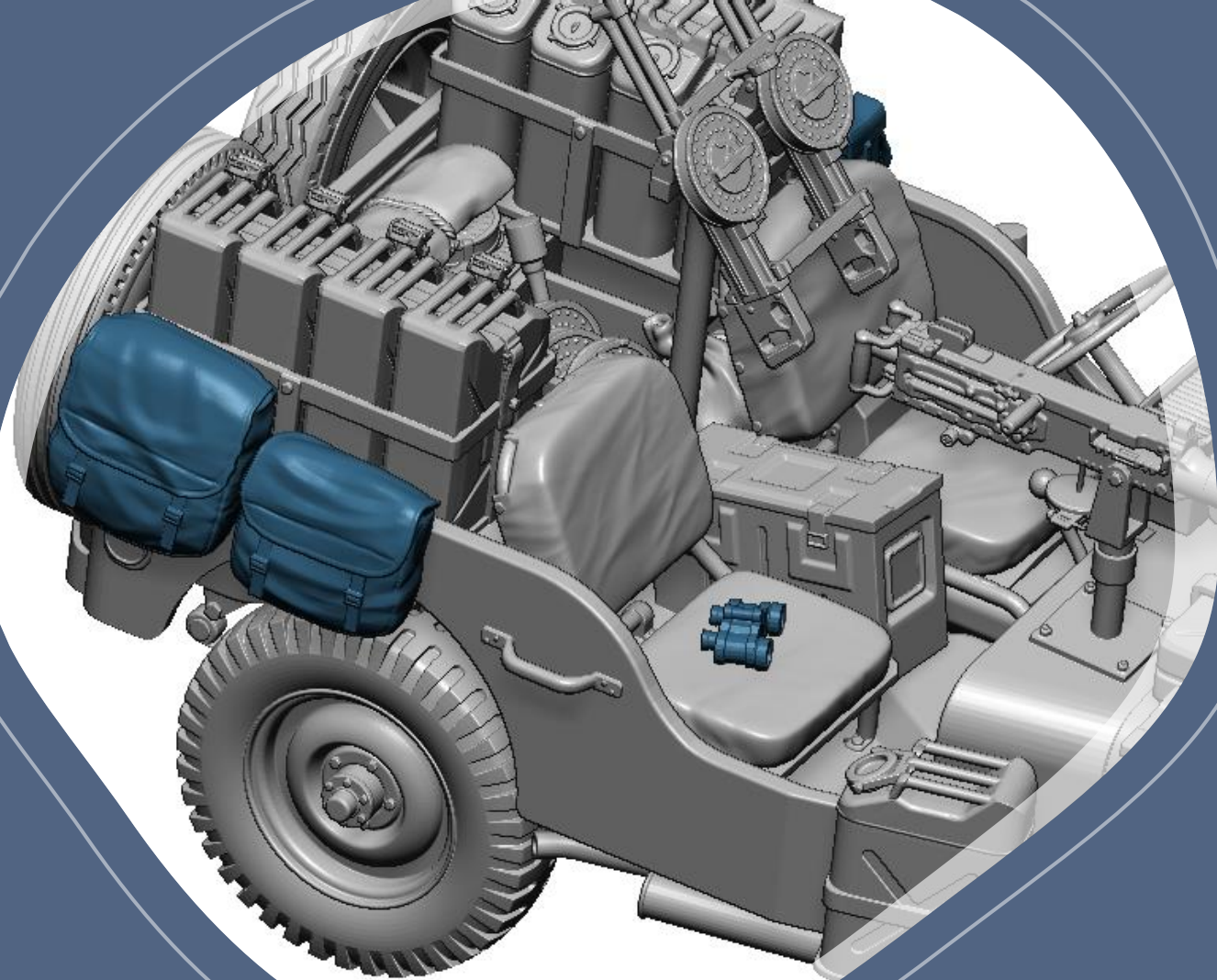

48A14
Exterior Equipment
Optional use

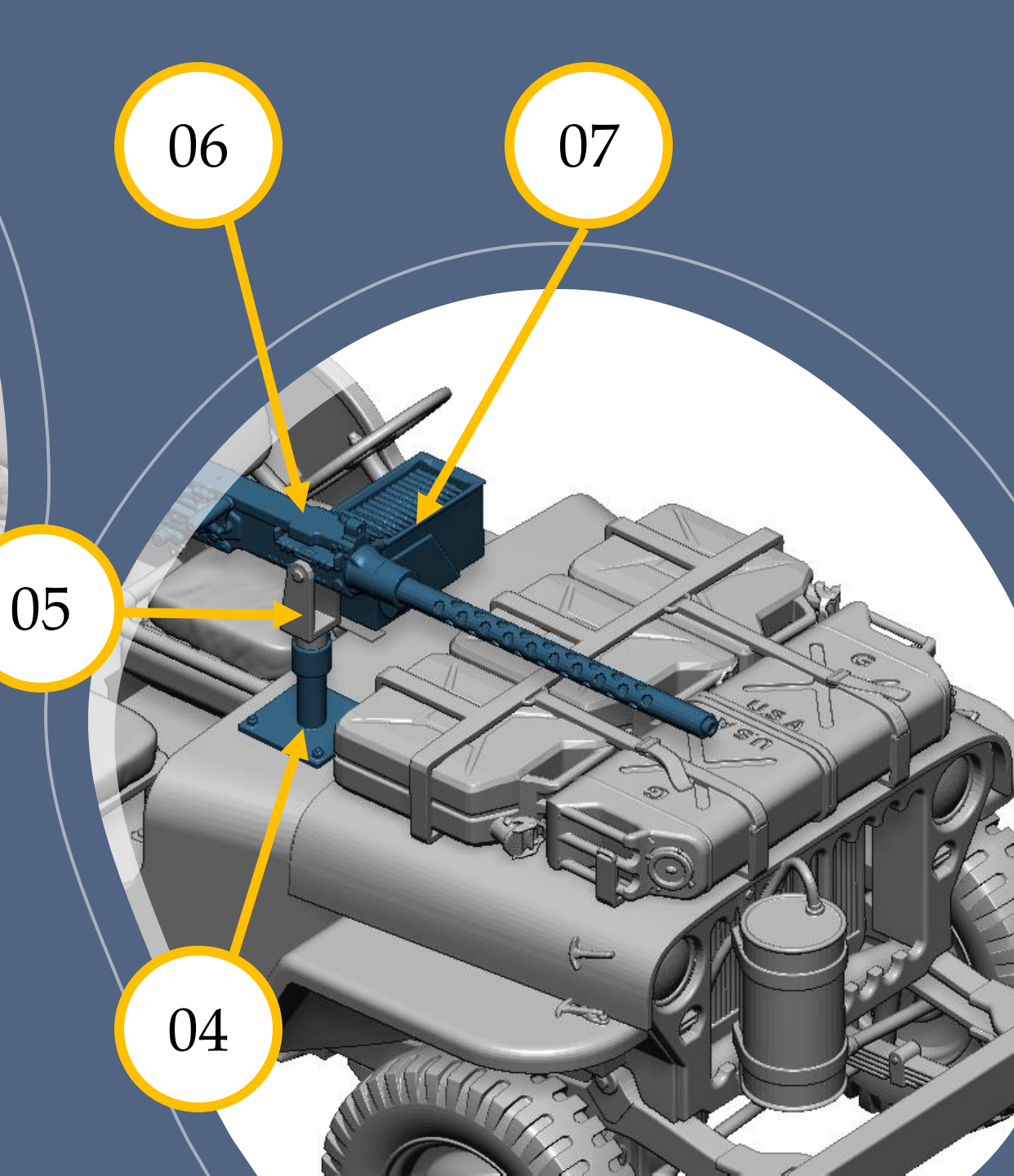
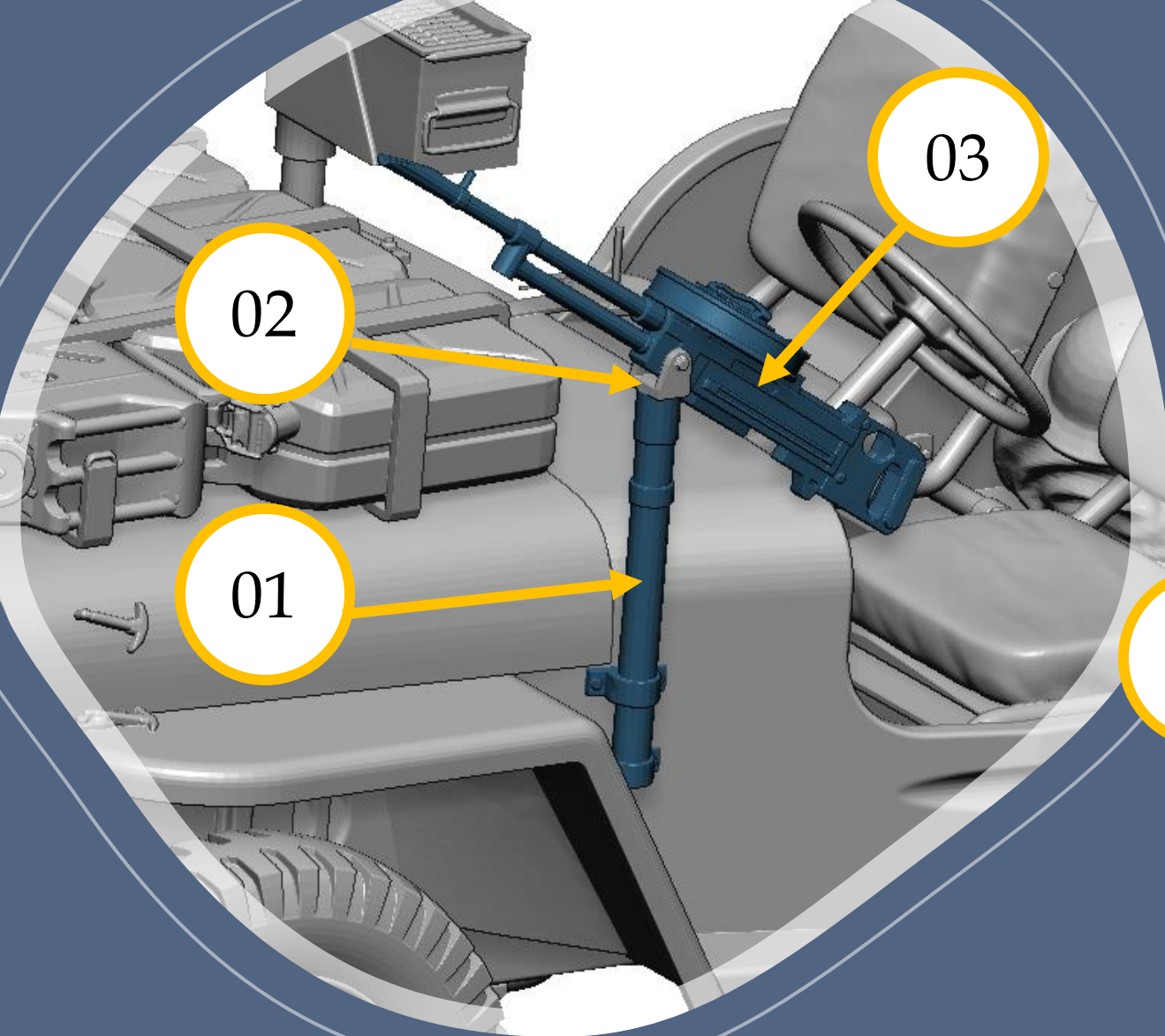

48A14
Armament

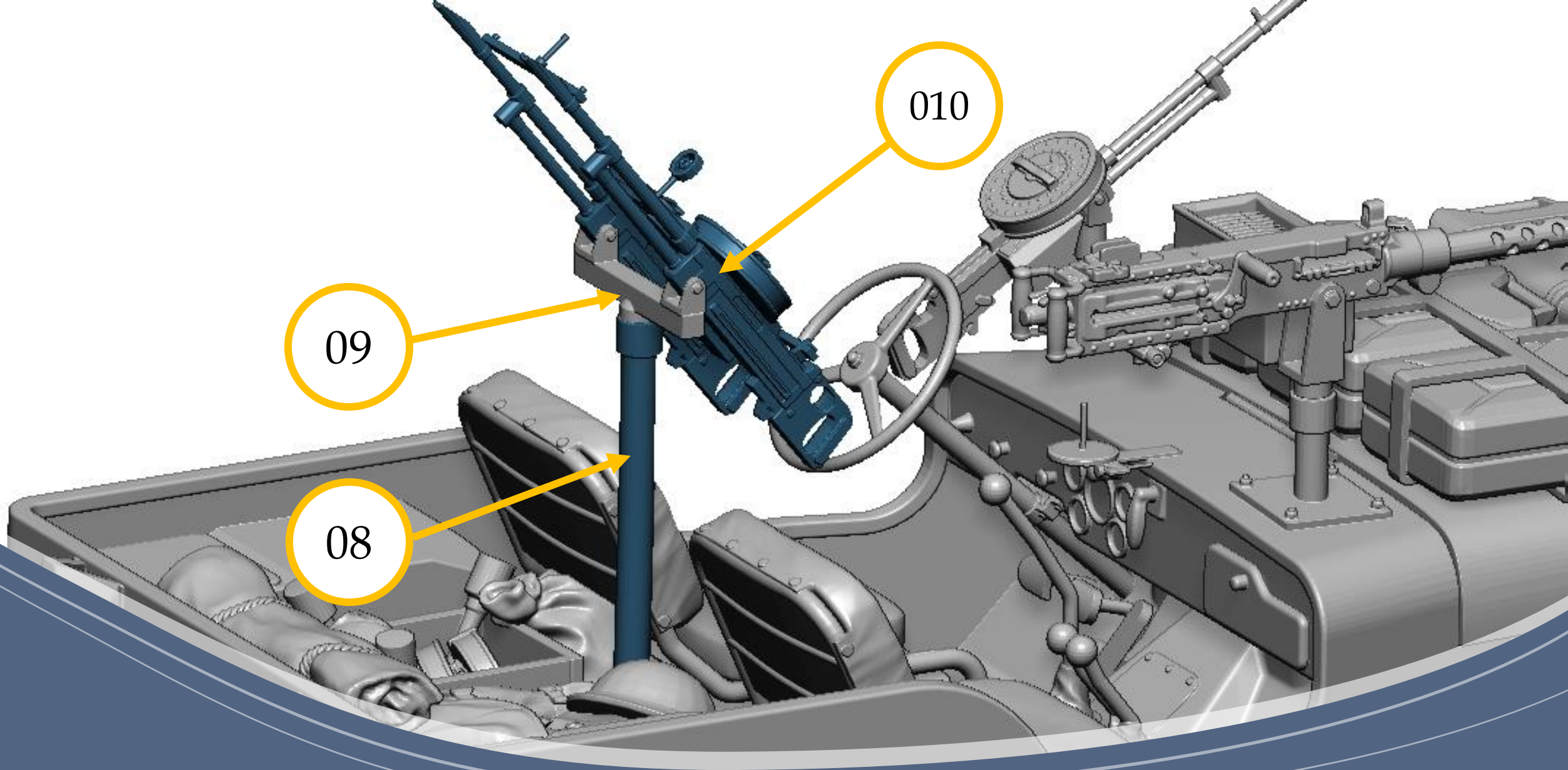

48A14
Armament

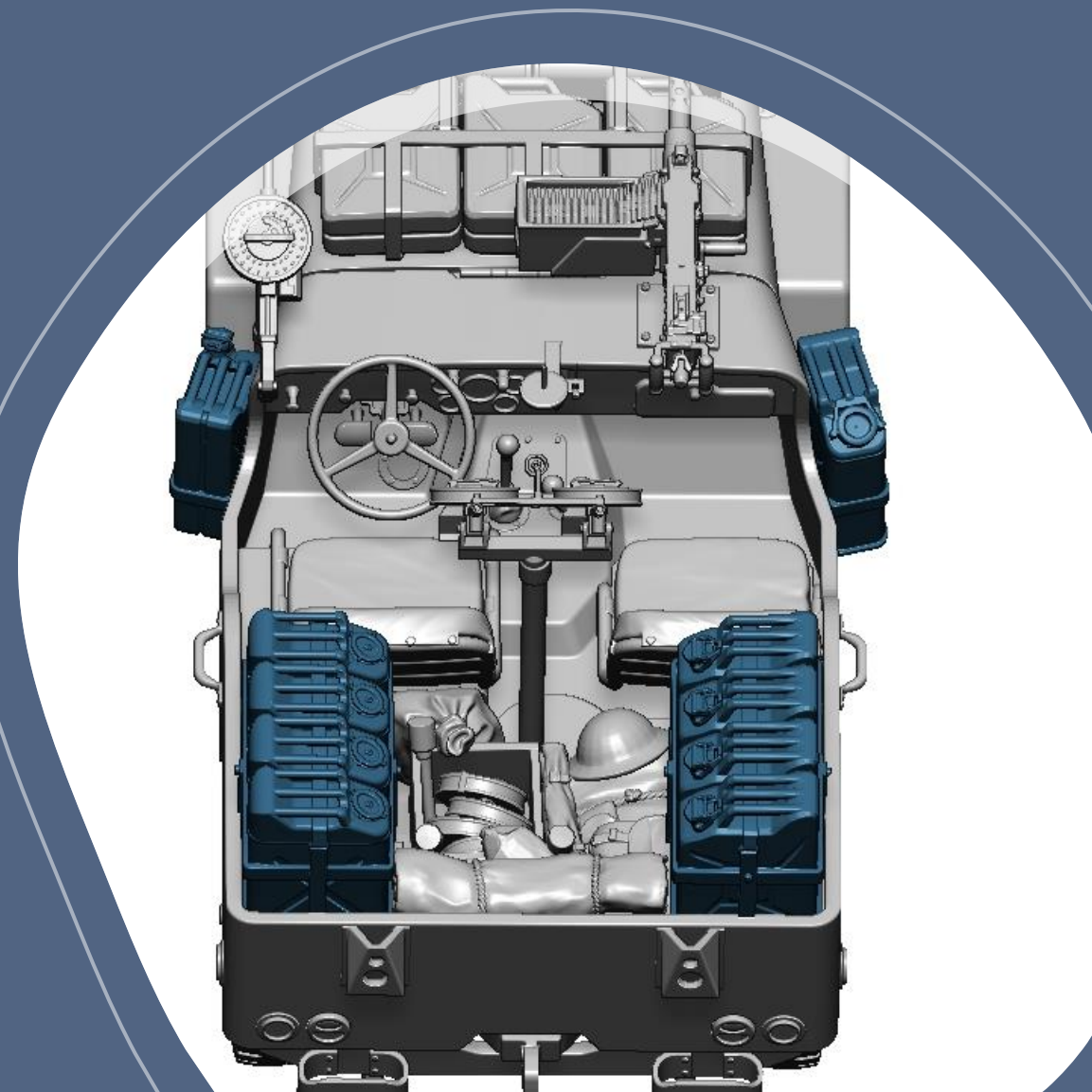
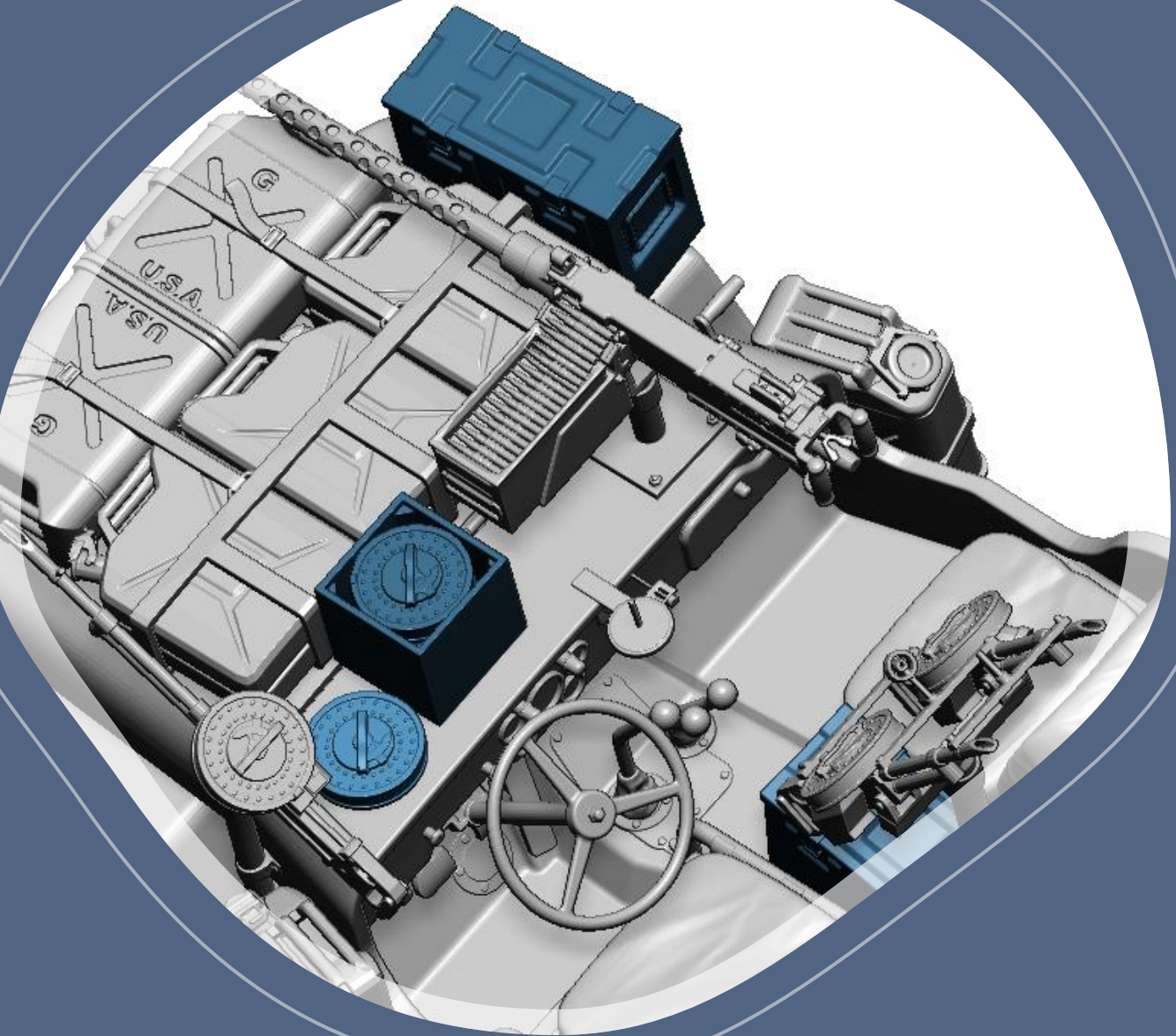

48A14
Ammo box & Fuel Tanks

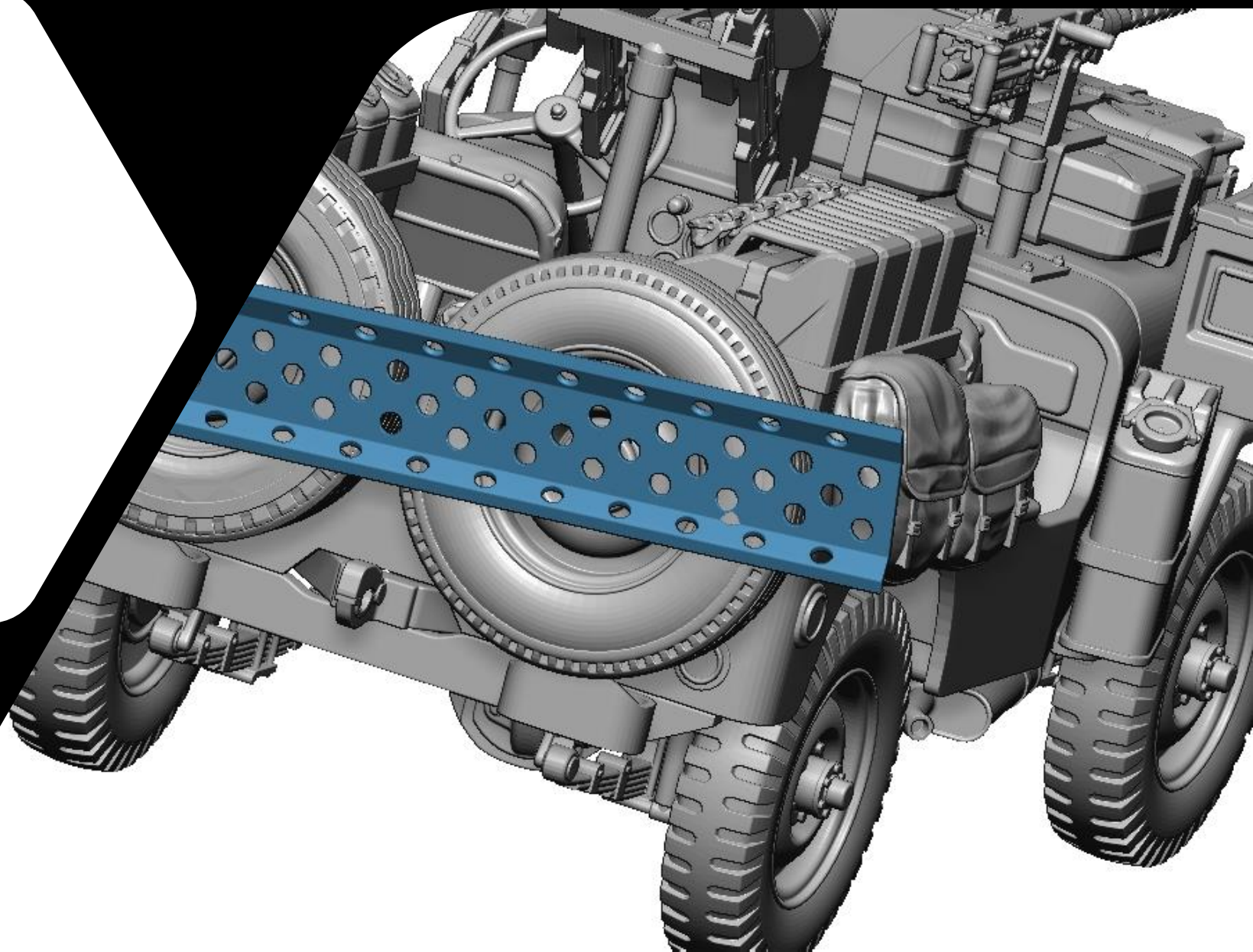
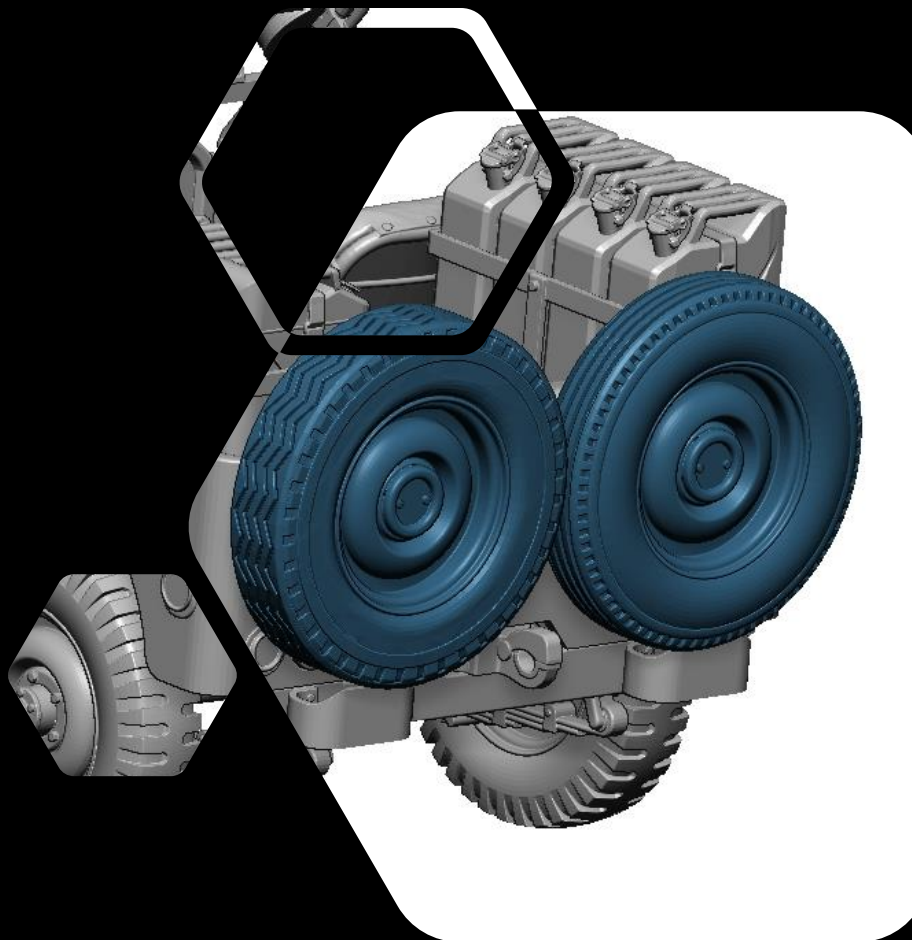

48A14
Nie wiem jak to
poprawnie nazwać



48A14
Paddy Maine

Special Air Service Jeep

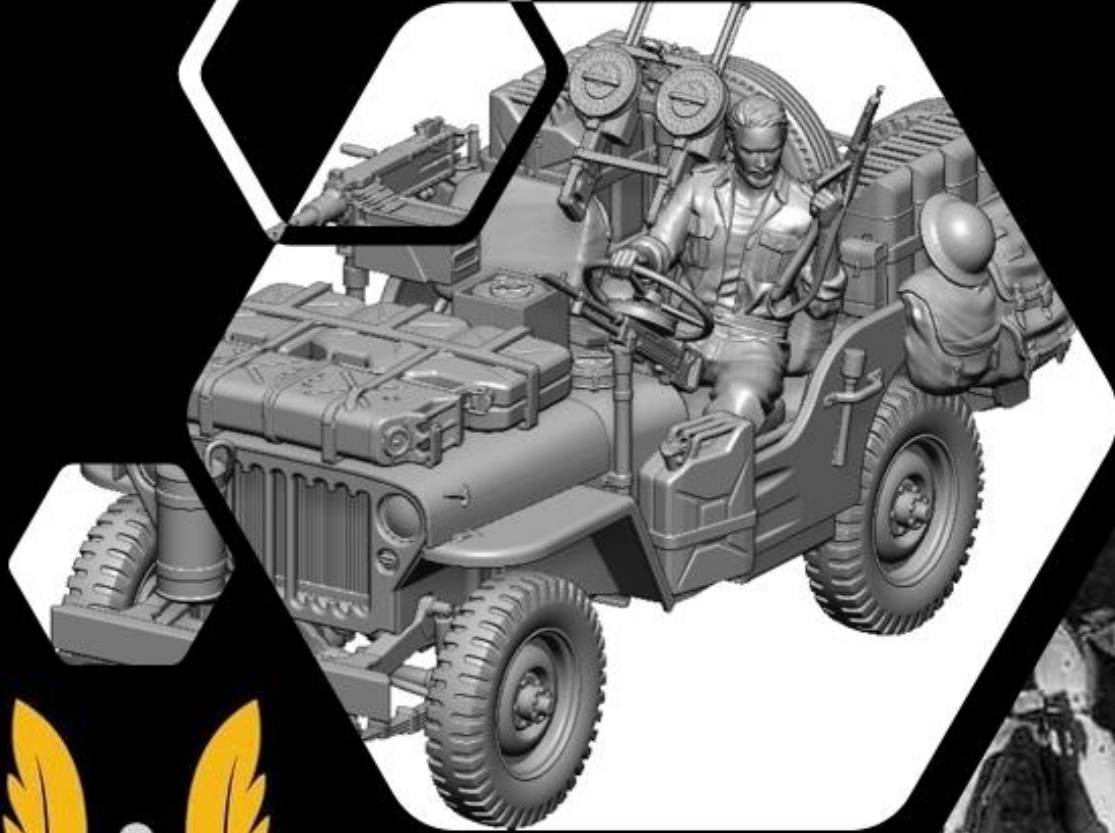

DOGFIGHT
WORKSHOP

